

# BrickML Box

## Edge ML device series

### User's Manual



---

BrickML is a low-power high-performance self-contained embedded device designed to run machine learning operations at the edge in industry settings.

---

#### KEY FEATURES

- MCU: 32-bit ARM<sup>®</sup> Cortex<sup>®</sup>-M33 core with FPU and 200 MHz clock speed
  - Up-to 2-MB program memory, 8-KB data flash, 128-Mbit on-board serial flash, 512-KB data memory
  - Communication: BLE 5.1
  - Sensors:
    - Knowles SPH0641LU4H-1 microphone
    - Bosch BNO055 9-DOF IMU
    - Renesas HS3001 high-performance T/H sensor
  - Supply Voltage: +5.0 V to +24 V single power supply
  - Operating Temperature Range: -20 °C to +70 °C
  - Dimensions: 89 x 79 x 33 mm
-

## Ordering Information

Table 1 – Ordering information.

Product Code	Variant	Description
RD-BML-1U	BrickML Box – USB	Boxed BrickML with USB support
RD-BML-1C	BrickML Box – CAN	Boxed BrickML with USB and CAN support
RD-BML-1E	BrickML Box – ETH	Boxed BrickML with USB, CAN and Ethernet support
RM-BML-1N	BrickML SoM – entry	BrickML module
RM-BML-1U	BrickML SoM – USB	BrickML module with USB support

## Outline

Ordering Information .....	2
1. Introduction .....	4
1.1. Module versions .....	4
1.2. Block diagram .....	5
2. Module Specifications .....	6
2.1. General specifications .....	6
2.2. BLE radio specifications .....	6
2.3. Nominal Electrical Operating Conditions .....	7
2.4. Absolute Maximum Ratings .....	8
3. Pin Definitions .....	9
3.1. Pin Numbering .....	9
3.2. Pin Description .....	9
4. BrickML dimensions .....	10
5. Certifications .....	11
5.1. Europe CE .....	11
5.2. UK UKCA .....	11
5.3. America FCC .....	11
6. Waste disposal .....	12
6.1. UK .....	12
6.2. IT .....	12
6.3. F .....	13
Revision History .....	14

# 1. Introduction

BrickML is a low-power high-performance self-contained embedded device designed to run machine learning operations at the edge in industry settings.

Brick-ML Box is a complete device that can be mounted directly on various kind of equipment to collect data (vibrations, temperature and humidity, noise, voltage) to be used for training a specific AI model for your application.

BrickML features on-board compute, sensing and communication capabilities, all packed in one compact industrial-grade dust and moisture resistant form factor. It is fully integrated into Edge Impulse's industry-leading edge ML platform, allowing for the easy addition of advanced AI algorithms.

BrickML minimizes development time and accelerates speed to market by providing customers with both a highly integrated flexible kit for custom development as well as ready-to-use trained edge ML models.

## 1.1. Module versions

In order to provide designer with maximum integration flexibility, a solderable module version is available with (RM-BML-1U) or without (RM-BML-1N) USB connector.

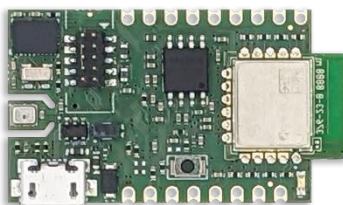

## 1.2. Block diagram

The basic block diagram is depicted in the image below. BrickML is built on Renesas RA6M5 MCU, a high-performance ARM Cortex-M33 featuring up to 2-MB flash memory and 512-kB of RAM. Several sensors are mounted on board for environmental, sound and motion data collection plus an analog voltage input.

Connectivity is provided by dedicated Ethernet, CAN, UART, USB high speed ports; moreover an additional BLE 5.1 module offers additional wireless connectivity.

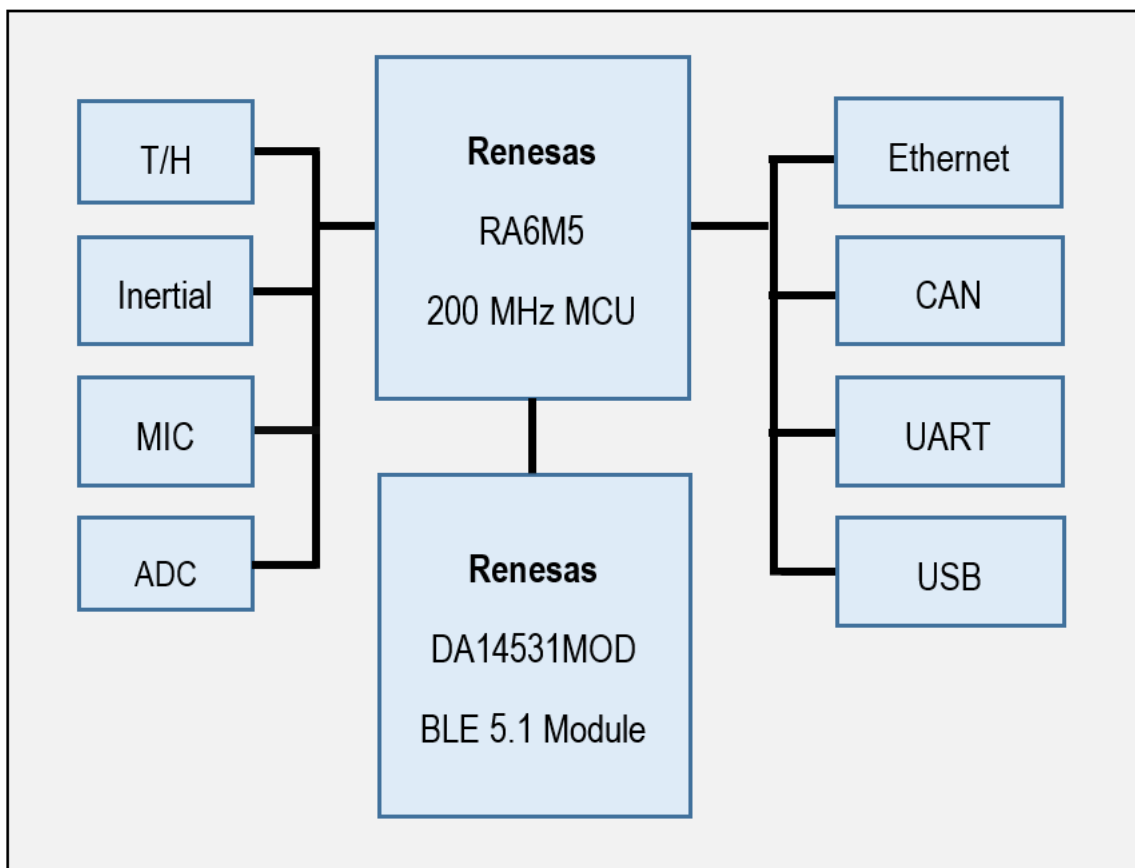

Figure 1 - BrickML block diagram

## 2. Module Specifications

### 2.1. General specifications

The following table describes the general specifications for the devices.

Table 2 – BrickML general specifications.

Specification	RD-BML-1U	RD-BML-1C	RD-BML-1E
Power supply USB	Yes		
Power supply external	-	Yes	
Operating temperature range	-40 to +70 °C		
Wireless Connectivity	BLE 5.1 - output 2.2 dBm		
USB Connectivity	High Speed		
CAN Connectivity	-	Yes	
Ethernet Connectivity	-	-	Yes
Analog input	-	Yes	
Dimensions	89.0 x 79.0 x 33.0 mm		

### 2.2. BLE radio specifications

Table 3 – BLE radio Recommended Operating Conditions.

Parameter	Description	Conditions	Min	Typ	Max	Unit
$f_{OPER}$	Operating frequency		2400		2483.5	MHz
$N_{CH}$	Number of channels			40		1
$f_{CH}$	Channel frequency	$K = 0$ to $39$		$2402 + K * 2$		MHz

Table 4 – BLE radio AC Characteristics.

Parameter	Description	Conditions	Min	Typ	Max	Unit
P <sub>O_12</sub>	Output power level	RF_ATTR_REG[PA_POWER_SETTING]= 12		2.5		dBm
P <sub>O_11</sub>	Output power level	RF_ATTR_REG[PA_POWER_SETTING]= 11		1.5		dBm
P <sub>O_10</sub>	Output power level	RF_ATTR_REG[PA_POWER_SETTING]= 10		1		dBm
P <sub>O_09</sub>	Output power level	RF_ATTR_REG[PA_POWER_SETTING]= 9		0		dBm
P <sub>O_08</sub>	Output power level	RF_ATTR_REG[PA_POWER_SETTING]= 8		-1		dBm
P <sub>O_07</sub>	Output power level	RF_ATTR_REG[PA_POWER_SETTING]= 7		-2		dBm
P <sub>O_06</sub>	Output power level	RF_ATTR_REG[PA_POWER_SETTING]= 6		-3.5		dBm
P <sub>O_05</sub>	Output power level	RF_ATTR_REG[PA_POWER_SETTING]= 5		-5		dBm
P <sub>O_04</sub>	Output power level	RF_ATTR_REG[PA_POWER_SETTING]= 4		-7		dBm
P <sub>O_03</sub>	Output power level	RF_ATTR_REG[PA_POWER_SETTING]= 3		-10		dBm
P <sub>O_02</sub>	Output power level	RF_ATTR_REG[PA_POWER_SETTING]= 2		-13.5		dBm
P <sub>O_01</sub>	Output power level	RF_ATTR_REG[PA_POWER_SETTING]= 1		-19.5		dBm

### 2.3. Nominal Electrical Operating Conditions

The following tables give detailed specifications for the BrickML devices.  $T_{amb} = 25\text{ }^{\circ}\text{C}$  for all specifications given, if not differently specified.

Table 5 – BrickML electrical specifications.

Parameter	Min	Typ	Max	Units	Condition/Notes
Power supply USB	4.75	5.0	5.25	V	
Power supply external	12		24	V	
Standby Current		1		$\mu\text{A}$	

## 2.4. Absolute Maximum Ratings

Table 6 – BrickML absolute maximum ratings.

Parameter	Min	Max	Units
Power supply external	-0.3	36	V
Storage Temperature	-40	+75	°C
Operating Temperature	-40	+70	°C
ESD (Human Body Model)		2000	V

Stresses beyond those listed in this table may cause permanent damage to the device. This is a stress rating only; functional operation of the device at these or any other conditions beyond those indicated in the operating conditions of the specification is not implied. Exposure to the absolute maximum rating conditions for extended periods may affect device reliability.

## 3. Pin Definitions

### 3.1. Pin Numbering

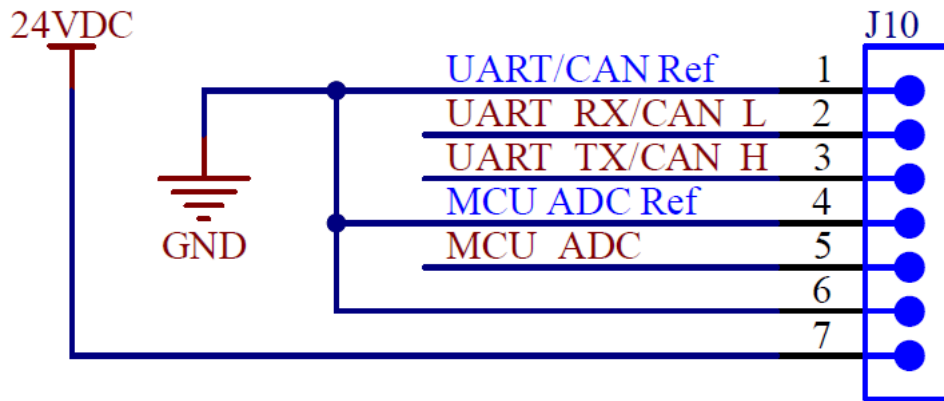

Figure 2 – BrickML pinout

### 3.2. Pin Description

Device pinout is detailed in the table below.

Table 7 – BrickML external connections and descriptions.

Pin #	Pin Name	Description
1	UART / CAN Ref	Reference ground for UART or CAN connection
2	UART_RX / CAN_L	UART RX or CAN Low line
3	UART_TX / CAN_H	UART TX or CAN High line
4	MCU_ADC_Ref	Reference ground for ADC input
5	MCU_ADC	ADC input (connected to P003 of the MCU)
6	GND	Ground Connection
7	VCC	Power Supply Input (12 V ÷ 24 V)

## 4. BrickML dimensions

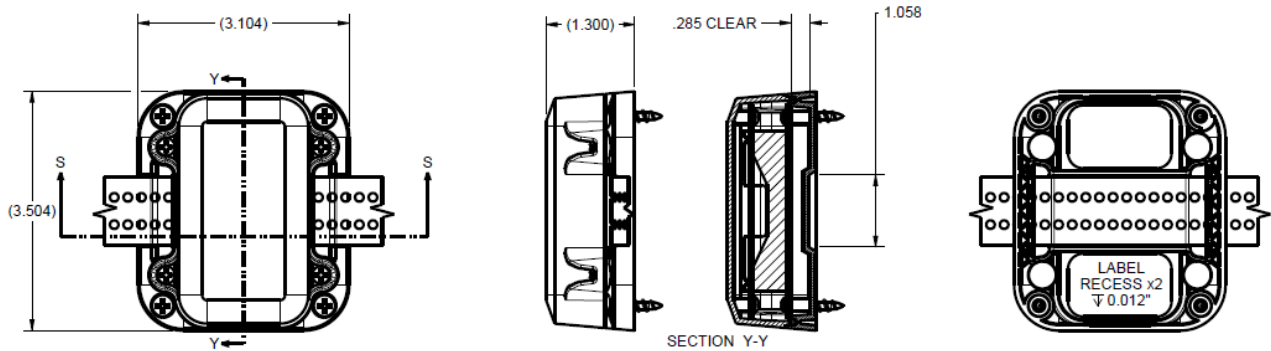

SCALE 0.500

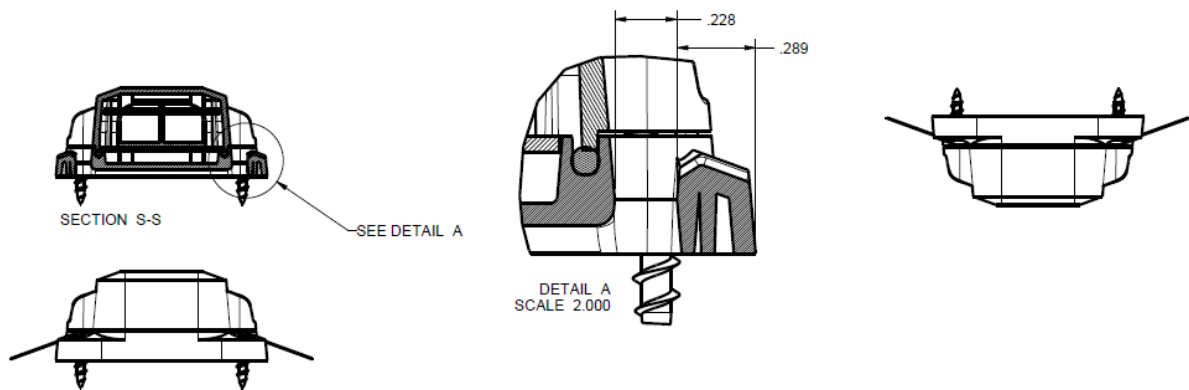

DETAIL A  
SCALE 2.000

## 5. Certifications

The BrickML devices comply with the laws and regulations described below.

### 5.1. Europe CE

Hereby, RELOC s.r.l. declares that the BrickML devices (RD-BML-1U, RD-BML-1C, RD-BML-1E, RM-BML-1N, RM-BML-1U) are designed and manufactured in compliance with the essential requirements and other relevant provisions of Directive 2014/53/EU.

### 5.2. UK UKCA

Hereby, RELOC s.r.l. declares that the BrickML devices (RD-BML-1U, RD-BML-1C, RD-BML-1E, RM-BML-1N, RM-BML-1U) are designed and manufactured in compliance with the essential requirements and other relevant provisions of Radio Equipment Regulations 2017 No. 1206.

### 5.3. America FCC

This device complies with Part 15 of the FCC rules subject to the following two conditions:

1. This device may not cause harmful interference.
2. This device must accept all interference received, including interference that may cause undesired operation.

## 6. Waste disposal

### 6.1. UK

Pursuant to legislation for the implementation of Directive 2012/19/EU on "Waste electrical and electronic equipment (WEEE)"



It is forbidden to dispose of electrical items and electronic equipment as municipal waste, as evidenced also by the symbol shown on the product and/or its packaging. These forms of waste are subject to separate collections organised by municipal authorities, or may be returned to the retailer when buying a new appliance of the same type. Improper disposal or misuse of such equipment or its component parts can damage the environment and human health due to the presence of hazardous substances. Illegal disposal of this waste is forbidden of the legislation currently in force.

### 6.2. IT

D.Lgs. 14/04/2014 n.49 "Attuazione della Direttiva 2012/19/UE sui rifiuti di apparecchiature elettriche ed elettroniche (RAEE)"



È vietato smaltire i rifiuti di apparecchiature elettriche ed elettroniche come rifiuti urbani, come evidenziato anche dal simbolo riportato sul prodotto e/o sulla confezione. Tali rifiuti sono soggetti a raccolta differenziata organizzata dai comuni o possono essere riconsegnati al distributore al dettaglio in caso di acquisto di una nuova apparecchiatura dello stesso tipo. Lo smaltimento abusivo o l'uso improprio di tali apparecchiature o parti di esse può danneggiare l'ambiente e la salute a causa della presenza di sostanze pericolose. Lo smaltimento abusivo di detti rifiuti è sanzionato ai sensi della corrente normativa.

### 6.3. F

Conformément aux réglementations d'application de la Directive 2012/19/UE sur les « Déchets d'équipements électriques et électroniques (DEEE) »



Il est interdit de jeter les déchets d'équipements électriques et électroniques avec les déchets ménagers, mais se référer au symbole figurant sur le produit ou sur l'emballage. Ces déchets font l'objet d'une collecte sélective organisée par les municipalités ou peuvent être retournés au fabricant lors de l'achat d'un nouvel appareil du même type. L'élimination inadéquate ou une mauvaise utilisation de ces équipements ou des parties de celui-ci, peuvent endommager l'environnement et la santé humaine en raison de la présence de substances dangereuses. L'élimination illégale de ces déchets est sanctionnée conformément au législation en vigueur.

## Revision History

REVISION	DATE	STATUS / COMMENTS	AUTHOR
0.1	21/04/2023	Initial release	AR
0.2	26/04/2023	Updated specifications	LDB
1.0	04/07/2023	First public release	LDB

**RELOC s.r.l.**

Registered and operative office  
Strada Langhirano 264/3A  
I-43124 Parma – Italy

**Web**

[www.reloc.it](http://www.reloc.it)

**Support e-mail**

[support@reloc.it](mailto:support@reloc.it)

Phone: +39-0521-649116

E-mail: [info@reloc.it](mailto:info@reloc.it)

All trademarks mentioned in this document are the property of their respective owners.

No part of the contents of this manual may be transmitted or reproduced in any form or by any means without the written permission of RELOC s.r.l.

Information in this document is subject to change without notice and does not represent a commitment on the part of RELOC.

RELOC provides this document “as is,” without warranty of any kind, either expressed or implied, including, but not limited to, the implied warranties of fitness or merchantability for a particular purpose. RELOC may make improvements and/or changes in this manual or in the product(s) and/or the program(s) described in this manual at any time. This document could include technical inaccuracies or typographical errors. Changes are periodically made to the information herein; these changes may be incorporated in new editions of the publication.

© RELOC s.r.l. 2023. All rights reserved.