

Proposal for Amendment 2 to UN GTR No. 21 on the determination of system power of hybrid electric vehicles and of pure electric vehicles having more than one electric machine for propulsion - Determination of Electrified Vehicle Power (DEVP)

Submitted by the Informal Working Group on Electric Vehicles and the Environment (EVE)*

The text reproduced below was prepared by the Informal Working Group (IWG) on Electric Vehicles and the Environment (EVE) following the authorization given by WP.29/AC.3 to consider revisions to this UN GTR (ECE/TRANS/WP.29/AC.3/XX/xxxx).

Contents

	<i>Page</i>
I. Statement of technical rationale and justification.....	3
A. Introduction	3
B. Technical background.....	3
C. Technical rationale and justification	19
D. Technical feasibility, anticipated costs and benefits	24
II. Text of the GTR	25
1. Purpose	25
2. Scope and application	25
3. Definitions	25
4. Abbreviations.....	28
5. Test conditions.....	28
6. Test procedure	30
7. Definitions of families	45
Annexes	
1 Identification of power determination reference points	46
2 Determination of speed of maximum power	50 _(SMI)

* In accordance with the programme of work of the Inland Transport Committee for 2020 as outlined in proposed programme budget for 2020 (A/74/6 (part V sect. 20) para 20.37), the World Forum will develop, harmonize and update UN Regulations in order to enhance the performance of vehicles. The present document is submitted in conformity with that mandate.

I. Statement of technical rationale and justification

A. Introduction

1. Passenger vehicles are commonly assigned a vehicle power rating, which is useful for comparing the performance of different vehicles. Vehicle power rating has also been used for other purposes such as vehicle classification, customer information, insurance, and taxation.
2. Historically, almost every passenger vehicle produced for the consumer market has been powered exclusively by an internal combustion engine (ICE). The vehicle power rating assigned to these conventional vehicles has customarily been the same as the rated power of the engine, as determined by an engine bench test. This is a convenient way to assign a power rating to a vehicle, because the engine power rating may then be applied to any vehicle that uses the same engine.
3. As a measure of real-world vehicle performance, this traditional measure is imperfect, since it does not account for the power lost in the drivetrain between the engine and the road. However, it has become well established and is generally accepted as a useful metric, in part because conventional vehicles have only one engine, and its full rated power is typically available for propulsion.
4. Today, electrified vehicles such as hybrid electric vehicles (HEVs) and pure electric vehicles (PEVs) with multiple drive motors represent an increasing share of the market. A vehicle power rating is not as easy to assign to these vehicles because they combine more than one propulsion source, such as an engine and an electric machine, or multiple electric machines.
5. For these vehicles, the available power depends on how the control system combines the power of each propulsion source when the driver demands maximum power. While it may seem that this would simply be the sum of the rated power of each component, this is not necessarily valid in practice. It will result in an overestimate if, for example, the electric machine is limited by the available battery power, or if the control system limits or reassigns some of the nominal capacity, such as to maintain traction or charge the battery.
6. Owing to the pressing need to reduce emissions of greenhouse gases (GHG) and other air pollutants, the market share of electrified vehicles is expected to grow in the future. This intensifies the need for a standard method for assigning a vehicle power rating to electrified vehicles.
7. Electrified vehicles and conventional vehicles are likely to coexist in the market for some time. Many existing regulations and procedures, such as WLTP, apply to both conventional and electrified vehicles, and require a power rating as an input. In order to be used equitably for such purposes, a power rating for electrified vehicles should be qualitatively and quantitatively comparable with the traditional engine-based power ratings of conventional vehicles.

B. Technical background

1. Primary technical challenges

8. Developing a test procedure and system power rating that fits the requirements presents two primary technical challenges:
 - (a) The first challenge is to identify a reliable and repeatable way to command a vehicle to deliver maximum power in a laboratory setting.
 - (b) The second challenge is to identify a comparable and valid basis for the system power rating and to identify the measurements and calculations necessary to produce it.

(a) *Commanding maximum power*

9. As part of their standards development efforts, SAE and ISO studied ways to elicit maximum power in a laboratory setting (more details about the Informal Working Group (IWG) on Electric Vehicle and the Environment (EVE), SAE and ISO activities related to the topic of power measurement of electrified powertrain can be found in the technical report of this UN GTR). This resulted in identification of a reliable and repeatable method to do this by use of the fixed-speed setting of a chassis dynamometer. The condition of maximum power is determined by driving the vehicle on the dynamometer at a series of fixed dynamometer speeds to find the maximum brake power of the dynamometer that the vehicle is able to run against. At each speed, the accelerator is rapidly and fully depressed for at least 10 seconds. The speed at which the dynamometer records the highest power is recorded. The system power is then determined at this fixed dynamometer speed.

(b) *Basis and measurements*

10. In early discussions, the IWG on EVE discussed a number of conceptually simple measurement bases for electrified vehicle power.

11. One very simple basis would simply measure the peak power delivered to the wheels. This would be compatible with all electrified vehicles regardless of their powertrain architecture. If also extended to conventional vehicles, it would rate all vehicles on a directly comparable basis, and would represent real-world power more effectively than the traditional measure because it includes the effect of losses in the drivetrain. However, for the same reason, this would result in power ratings that are not comparable to the traditional measure, which continues to be used in many applications.

12. Another simple approach would measure the peak power delivered to the wheels and then adjust it by an assumed transmission efficiency. This approach recognizes that an engine-based power rating, in theory, should be identical to the peak power delivered to the wheels divided by the mechanical conversion efficiency of the drivetrain (e.g. gearbox or transmission). By extension, a highly comparable power rating for an electrified vehicle could be determined by measuring the peak power delivered to the wheels and dividing by a typical (conventional) drivetrain efficiency at peak load, perhaps 90 to 95 percent. However, it was not clear that this approach would represent all hybrid powertrains equally, nor that a single assumed drivetrain efficiency would represent all comparison vehicles equally.

13. Another possibility would sum the power of the engine with the measured power output of the battery. Many hybrid vehicles operate the engine at full throttle when the driver demands maximum power, meaning that engine power can be estimated from engine speed by reference to a full load power curve. Battery power is also reasonably simple to measure, and measuring at the battery avoids the need to instrument individual inverters or motors. However, it would neglect electrical conversion losses in the latter, and so might tend to produce optimistic results for highly electrified powertrains.

14. Recognizing that these relatively simple methods vary in their comparability and fairness, the IWG on EVE sought to identify a more sophisticated approach.

15. Conceptually, a comparable and fair rating would be based on the power that passes through the powertrain at a point that is mechanically analogous to the output shaft of a conventional engine (as opposed to the wheels or the battery, where the losses would be different). Intuitively, this point would include the mechanical output shafts of any propulsion energy converters (i.e. engine and electric machines) that contribute propulsion energy when the driver commands maximum power.

16. As an example, Figure 1 illustrates a typical P2 hybrid configuration, in which ICE power and electric motor power is mechanically combined on a single shaft. It identifies two "reference points," R1 and R2, which together are mechanically analogous to the power output of the engine in a conventional vehicle. That is, they represent where the mechanical power that drives the wheels is first produced from stored energy. The goal would be to determine the sum of the mechanical power passing through R1 and R2 when the vehicle is producing maximum power.

Figure 1
Example of reference points for system power determination

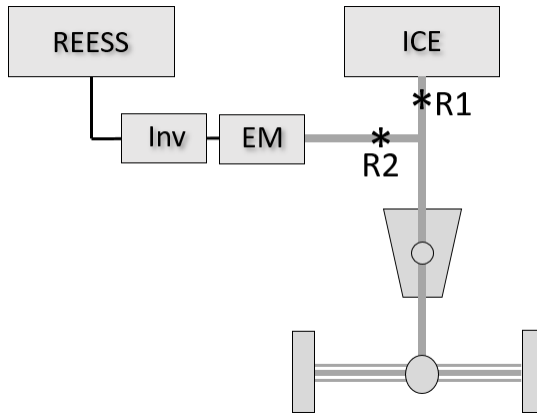

17. In theory, the most direct approach to measure the power at R1 and R2 would be to instrument the corresponding shafts with torque and speed meters. However, this requires invasive instrumentation, may not be possible in some cases, and is unlikely to be practical in a type approval context.

18. A more practical approach would measure power flow at other points in the powertrain that are easier to instrument, and estimate the power at reference points R1 and R2 by accounting for the losses between the measuring points and the reference points. As shown in Figure 2, the measuring points could either be upstream or downstream of the reference points. An option for measuring upstream (option 1) might include measuring engine speed and converting it to the mechanical power output at R1, and measuring REESS power output and converting it to the power at R2 by accounting for electrical conversion losses. Options for measuring downstream (option 2) might include measuring the power delivered to the axle by means of wheel torque and speed sensors or a hub dynamometer, and then determining the sum of R1 and R2 by accounting for mechanical conversion losses in the drivetrain.

Figure 2
Possible measurement points to estimate power at R1 and R2 for parallel P2 hybrid

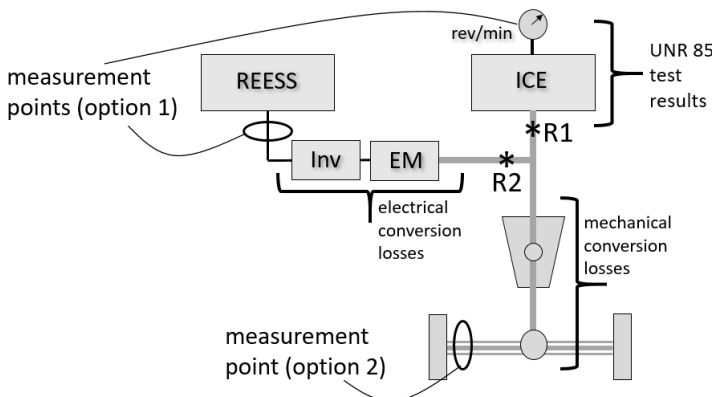

Note: measurement point for option 2 represents both axle shafts.

19. Electrified powertrains vary widely, and can include power flow paths that are much more complex than those depicted here. However, once the reference points are identified, it should be possible to estimate the power at the reference points by taking appropriate measurements when the vehicle is generating maximum power, and accounting for the losses between the measurement points and the reference points using component test data or sound engineering judgement.

2. Accuracy and precision

20. It should be noted that the traditional engine-based metric does not perfectly represent the road power available to the driver, because it neglects losses in the transmission. This also makes it imprecise, in that the road power may vary significantly from one vehicle model to another due to differences in drivetrain losses.

21. Engine power ratings are also somewhat imprecise. For example, UN Regulation No. 85 allows the declared power value for a production engine to vary by ± 2 percent from the certification test result, and by ± 5 percent for conformity of production.

22. A system power metric for electrified vehicles might therefore be held to a similar level of accuracy and precision.

3. Work of other organizations

23. The IWG on EVE received presentations from experts with several organizations that were studying the problem of hybrid system power determination.

(a) SAE J2908

24. The SAE J2908 Task Force led by Argonne National Laboratory (ANL) started its project in November 2014. Three primary methods of determining HEV system power were initially investigated (referred to here as Method 1, Method 2, and Method 3).

25. SAE Method 1 was the sum of engine power (estimated from bench test results) and measured DC power from the battery (neglecting electrical conversion losses in the inverter and electric machines). SAE Method 2 was the sum of estimated shaft powers from the engine and the electric machines (determined from bench test results and onboard data, respectively). SAE Method 3 was the measured power at the axle or wheel.

26. The IWG on EVE agreed with the characterization of these three primary methods as reasonable approaches to measure system power. However, the three methods varied in terms of how well the measure could be compared to the traditional power ratings for conventional vehicles, and in terms of the ability to verify a reported value. Method 1 was conceptually similar to the conventional engine-based rating and would be straightforward to verify by measurement, but neglected some losses. Method 2 was most comparable to the conventional rating, but would impose the highest burden of instrumentation to verify. Method 3 would be easily verifiable by dynamometer testing, but because a wheel power measurement accounts for losses in the drivetrain, it would not be as comparable to the conventional rating, which does not.

(b) KATRI standard

27. KATRI started a research project in July 2013 with the aim of developing a national standard for the determination of a representative power for (Non) Off-Vehicle Charge ((N)OVC)-HEVs and PEVs with in-wheel motors. It was completed in June 2015. Nominal rating and system power tests were studied using a powertrain dynamometer or a chassis dynamometer with added instrumentation. The definition of hybrid system power follows the same approach as SAE Method 1, namely that it involves a simple addition of the rated engine power and the electric power of the battery. The engine power is the rated power according to UN Regulation No. 85. The electric power is the measured power of the fully charged REESS, determined by chassis dynamometer testing. Compared to the SAE methodology, it is a somewhat more sophisticated test that provides not only accurate measurement of wheel or axle power but also system torque.

(c) ISO 20762

28. ISO conducted a project under New Work Item Proposal (NWIP) N3477 proposed by the Japan Automobile Research Institute (JARI), approved in June 2015. It started as a formal project of ISO/ TC22/SC37/WG02 and was finalized as ISO Standard 20762 in 2018.

29. The ISO method includes two alternative test procedures, referred to as test procedure 1 (TP1) and test procedure 2 (TP2).

30. As shown in Figure 3, TP1 is based on upstream measurements at the engine and REESS, and TP2 is based on a downstream measurement at the wheel hubs or axle shafts.

Figure 3
Measurement points for ISO test procedures TP1 and TP2

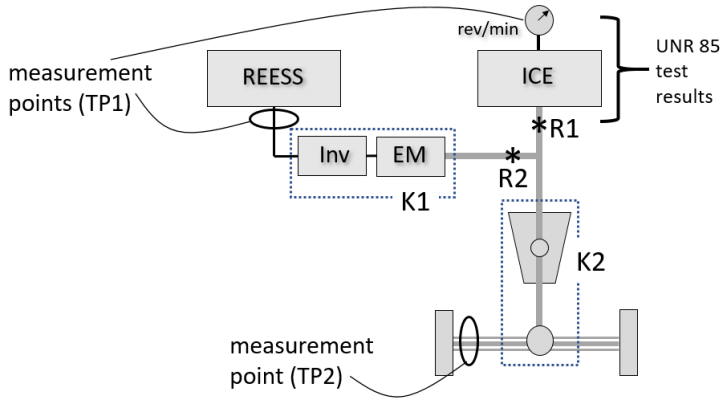

Note: measurement point for TP2 represents both axle shafts.

31. TP1 is similar to SAE Method 1, but additionally accounts for electrical conversion losses. Total power is the sum of estimated engine power and estimated motor power. Engine power is the rated power by ISO 1585 (or UN Regulation No. 85) at the observed operating point. Motor power is based on measured REESS power, adjusted by a factor (known as K, with a default value of 0.85) that represents combined efficiency of the inverter(s) and electric machine(s). (Electrical power to the accessories is also estimated or measured and deducted from the REESS power.) Figure 4 illustrates how total power is modelled under TP1.

Figure 4
TP1 as sum of estimated engine power and estimated motor power

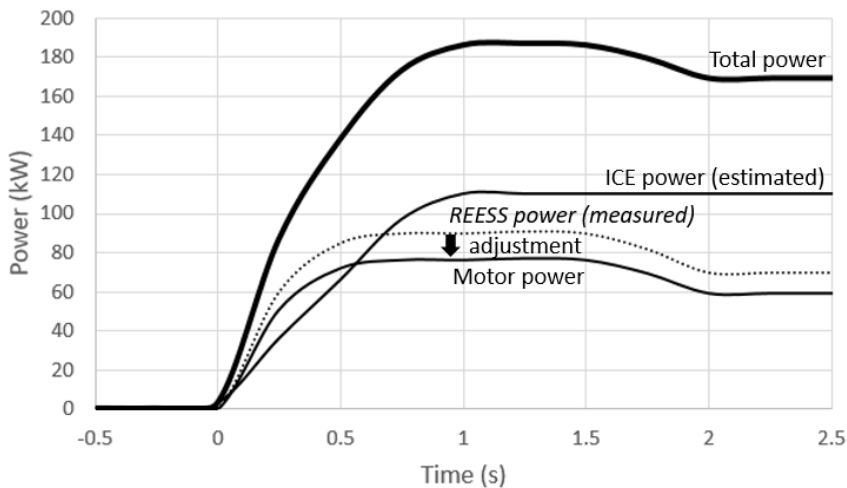

32. TP2 is similar to SAE Method 3. Total power is the power measured at the wheels or axle shafts, adjusted by a factor (known as η_{gb}) that represents losses in the gearbox. Default values for η_{gb} are provided for a number of hybrid drivetrains. Figure 5 illustrates how total power is modeled under TP2.

Figure 5
TP2 as measured wheel power adjusted for losses in gearbox

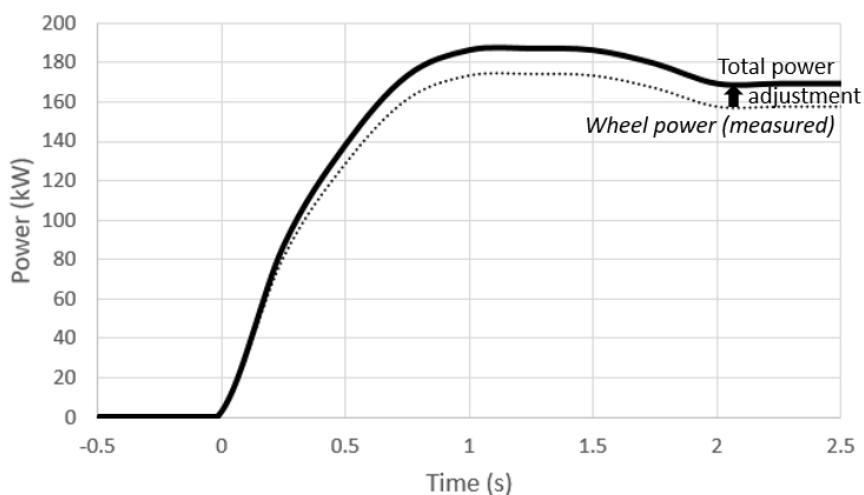

33. It could be said that TP1 and TP2 provide the flexibility in measurement options provided by SAE Method 1 and 3, while the inclusion of the adjustment factors K and η_{gb} result in a metric more like that of SAE Method 2, which is most comparable to the traditional measure.

34. In both TP1 and TP2, power is measured when the hybrid system as a whole delivers maximum power on a dynamometer running at a fixed speed. If not provided by the manufacturer, the fixed speed at which maximum power is delivered is determined by carrying out a series of test runs while driving the vehicle on the dynamometer at a series of fixed speeds to find the maximum brake power of the dynamometer that the vehicle is able to run against. At each speed, the accelerator is rapidly and fully depressed for at least 10 seconds.

35. As shown in Figure 6, the tests result in a power-versus-speed curve that helps to identify the fixed dynamometer speed at which maximum power is generated. If necessary, the evaluation is continued with smaller speed steps near the peak of the curve until the speed of the peak power is accurately identified. The power test is then performed at this fixed speed.

Figure 6
Identification of speed of maximum vehicle power

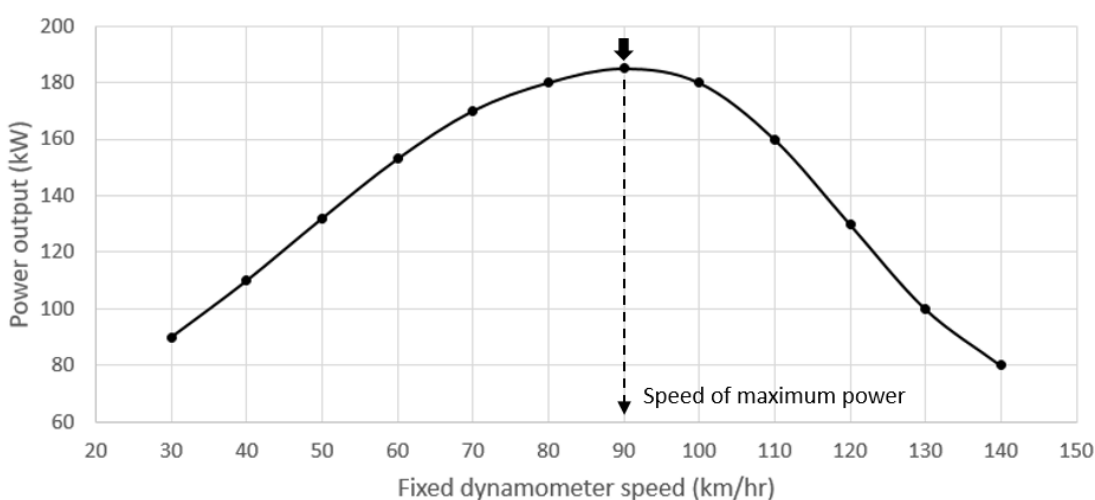

36. Calculations are then performed to determine the system power according to TP1 or TP2. As shown in Figure 7, a "peak" power is defined as the maximum value of a 2-second moving average of the total power over a 10 second window beginning at the start of

maximum accelerator command, and a "sustained" power is the average total power between the 8th and 10th seconds.

Figure 7

Definition of peak and sustained power

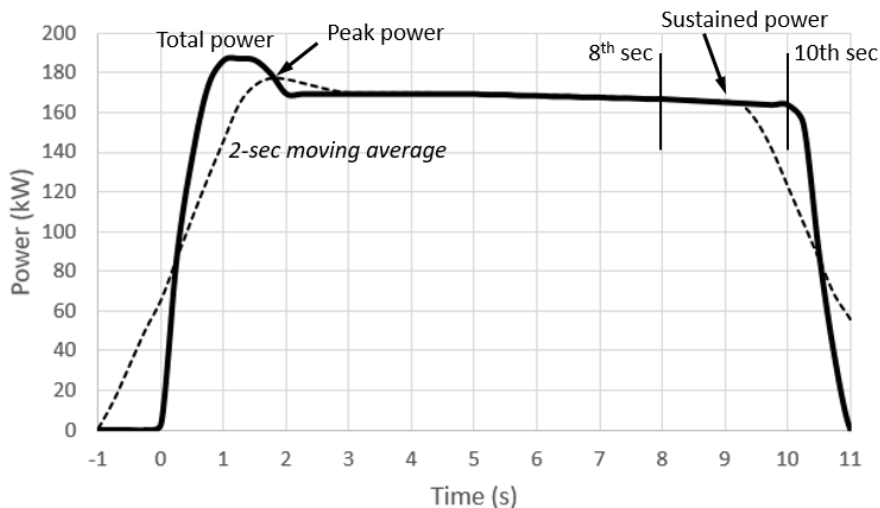

4. Selection of ISO methodology

37. The IWG on EVE recognized that the ISO method showed good comparability, flexibility, and verifiability. At the 22nd meeting of the IWG on EVE, the contracting parties reached consensus that the ISO approach presented the best option as a basis to fulfill the needs of the mandate.

5. Integration and validation

38. The IWG on EVE then turned attention to aligning and integrating the ISO method with UN GTR No. 15, or developing a new GTR. There was some debate as to whether the GTR should select only one of the ISO test procedures (TP1 or TP2) or retain both options. It was generally decided that retaining both would be preferable because it would accommodate variations in vehicle instrumentation possibilities and differing laboratory capabilities or preferences.

39. The IWG on EVE recognized that retention of both procedures meant that differences between the two test results should be minimized in order to prevent inconsistent results and the opportunity for selective reporting (or "cherry picking").

40. In designing and validating the ISO method, the ISO committee placed strong emphasis on its practicability. Testing at the Japan Automotive Research Institute (JARI) indicated that the procedures delivered equivalent results for a variety of HEVs, although TP2 was thought to show somewhat greater variability than TP1. Discussion in the IWG suggested that the relative variability may be the result of TP2 being based entirely on measured data, while a large component of TP1 relies on a fixed value for engine power obtained from the UN Regulation No. 85 rated power. If so, then the relative variability may be a natural outcome of differences in the procedures.

41. The IWG on EVE recognized that additional validation testing would be necessary to assess this and other potential sources of variability, and also to validate the ability of the aligned ISO method to fulfil the specific needs of a regulatory application.

42. Several contracting parties volunteered to perform validation testing, including Environment and Climate Change Canada (ECCC), Joint Research Centre (JRC), U. S. Environmental Protection Agency (EPA), and KATRI.

43. A first phase of the validation program was initiated at the April 2018 IWG on EVE meeting in Tokyo. Japan reviewed the testing performed on three HEVs in conjunction with

development of the ISO standard in 2016. A matrix of additional HEVs that were available for testing was compiled. US EPA offered to perform testing of a Belted Alternator Starter (BAS) hybrid and a power split PHEV. Canada offered to perform testing of a later generation power split HEV, a P2 hybrid, and a two-motor PEV. KATRI offered to perform testing on a P2 hybrid. JRC offered to perform testing on two parallel hybrid vehicles provided by representatives from Volvo and Hyundai.

44. Japan arranged for consultation with the engineer who performed the ISO validation tests in Japan. A detailed technical report on this testing had been prepared in Japanese. Canada agreed to arrange for translation of the report into English. JRC scheduled an initial round of testing at the facilities in Ispra, Italy in 2018, which was attended by representatives from USA and Japan as well as technical support personnel from Volvo and Hyundai.

45. Due to the short time frame available, and the knowledge that the ISO committee had already performed significant validation, the validation testing focused primarily on practicability of the procedure as currently written, and the effect of default assumptions and available flexibilities on the consistency of the results. To save time, testing was limited to vehicles that were readily available at the participating test labs and calculations were performed using the specified default values for K (later renamed K1) and η_{gb} (renamed K2). In some cases, measurements were gathered from onboard systems rather than instrumentation due to resource constraints. While the measurements were believed to be sufficiently accurate, it was not always possible to validate onboard measurements for accuracy.

46. The results of the first phase of validation revealed significant and unexpected differences between the results of TP1 and TP2 for many of the vehicles tested. Accordingly, the work of the IWG began to focus on identifying the sources of these differences, their implications, and how to reduce or eliminate them.

6. Causes of differences between TP1 and TP2 observed in Phase 1 of validation

47. The IWG on EVE identified several potential causes for the observed differences:

- (a) Variation in accuracy of default values for K1 and K2 as applied to specific vehicle models.
- (b) Uncertainty in accuracy of measurements and measurement options.
- (c) Variation in power of production engines compared to UN Regulation No. 85 test results.
- (d) Influence of powertrain architecture on necessary measurements to perform TP1 or TP2 in an equivalent manner.

(a) *Default values for K1 and K2*

48. For a given powertrain architecture and vehicle model, the relative accuracy of the fixed default values for K1 and K2 are likely to vary, leading to differences in the accuracy with which each TP accounts for losses, and thereby leading to a difference in the results.

49. In particular, the default K1 value of 0.85 sometimes appeared to produce lower power ratings for TP1, depending on the fraction of total power contributed by electricity. For one vehicle that was propelled entirely by electrical power, the power rating delivered by TP1 was smaller than the power measured at the wheels (which would erroneously suggest a drivetrain efficiency greater than 100 percent). Modifying the K1 value to a different value that was still consistent with the powertrain design made the result much closer to that of TP2.

50. For some powertrain architectures, the applicable default K2 factor for TP2 was unclear. Two of the test laboratories independently chose to employ different K2 values for an architecture that included series and parallel elements.

51. It was anticipated that the predefined list of default K2 factors may be insufficient to represent potential architectures that may emerge in the future. In particular, Japan pointed

out that it is uncertain whether the default value for K2 would apply to different variations in power split hybrid architectures.

(b) *Accuracy of measurements*

52. Some of the validation tests relied on TP1 measurements that were based on onboard network data that could not be verified because physical instrumentation for current and voltage was not available. While believed to be accurate, any inaccuracy could have contributed to the difference between TP1 and TP2.

53. Measurements for TP2 were taken from dynamometer rollers and therefore included tire losses. While the test procedure permitted the use of roller data if tire losses were accounted for, it did not specify a method for determining tire losses. Evidence of tire slippage was observed, which may have introduced additional unaccounted losses.

(c) *Variability of UN Regulation No. 85 engine power*

54. TP1 may be affected by allowable variation in engine power from UN Regulation No. 85 test results. According to Section 5.4 of UN Regulation No. 85 (Interpretation of results), the declared power output of production engines certified under UN Regulation No. 85 is permitted to vary by ± 2 percent from the test result, suggesting that some error is possible even if the measured engine speed and intake manifold pressure match perfectly with those reported in UN Regulation No. 85. This uncertainty is unique to TP1 and so could contribute to the observed variation between TP1 and TP2.

55. Further, TP1's estimation of engine power based on measured speed relies on the assumption that the engine is operating at its maximum power for that speed, and that the power can be accurately reconstructed by reference to engine test results (e.g. UN Regulation No. 85). Measurements of intake manifold pressure and fuel flow rate are compared to the engine test result to verify that the engine operating state is consistent with maximum power. However, the test procedure did not specify the permissible variation, leading to uncertainty in the engine power portion of TP1.

56. Some experts noted that intake manifold pressure is not highly sensitive to power output at the constant engine speed that results from the procedure, and therefore it is not highly effective at confirming the result. It was recommended that measurement of fuel flow rate also be required for verification of UN Regulation No. 85 engine power.

(d) *Influence of powertrain architecture*

57. ISO 20762 does not mention the concept of reference points, although reference points are implied by the details of the procedure. When the concept of reference points was introduced and applied rigorously, it was found that for some powertrain architectures, the then-prescribed calculations for TP1 and TP2 may have been estimating power at slightly different reference points, leading to variation between the results.

58. As shown in Figure 8, both TP1 and TP2 apply well to a parallel P2 HEV. Here, the system power is the sum of the power at R1 and R2. The K1 and K2 factors represent the conversion efficiencies of simple component combinations, and so are relatively simple to determine and verify. TP1 determines engine power at R1 by reference to speed and UN Regulation No. 85 results, and determines the power at R2 by measuring power from the REESS (subtracting accessory power) and applying the K1 efficiency factor. Alternatively, TP2 determines the sum of the power at R1 and R2 by measuring power at the axle shafts and applying K2. If the applicable measurements and K factors are equally accurate, then for this powertrain architecture, TP1 and TP2 should always deliver the same answer for the sum of R1 and R2.

Figure 8
Parallel P2 hybrid with one electric machine, measurable by TP1 and TP2

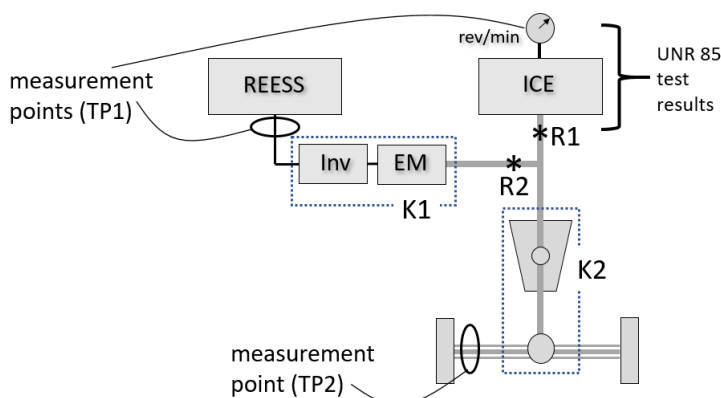

Note: measurement point for TP2 represents both axle shafts.

59. However, in the case of some other architectures, the specified measurements for TP1 or TP2 may be difficult to convert to a common reference point.

60. As shown in Figure 9, the Toyota Hybrid System (THS) utilizes a planetary gear set with multiple inputs and outputs. Under maximum power demand, engine power enters through the planet gear carrier (P), then is split between the ring gear (where it goes directly to the wheels) and the sun gear S (where it enters a series path that eventually delivers additional torque to the ring gear for delivery to the wheels).

Figure 9
Power split hybrid, ambiguous under TP2
P = planet carrier and gears; S = sun gear; Ring = ring gear

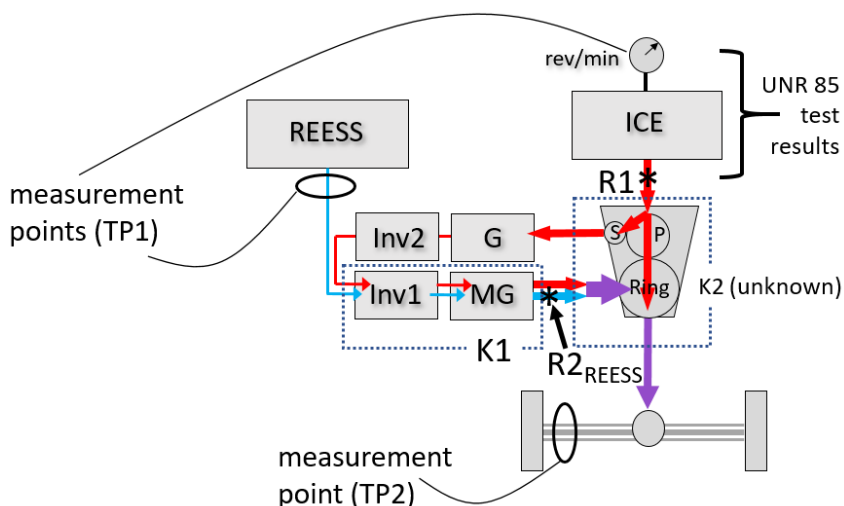

Note: measurement point for TP2 represents both axle shafts.

61. With careful consideration, reference points that are most comparable to a conventional vehicle can be identified. Reference point R1 represents where mechanical power from the engine is first produced. From here, the engine power splits to the series path and the direct-to-wheels path, which together may be considered as a sort of electro-mechanical transmission, and therefore, as with the transmission of a conventional vehicle, is not subject to further accounting.

62. Another reference point must be established to account for the contribution of the REESS. REESS power is first produced as mechanical power at the output shaft of motor-generator power at the output shaft of motor-generator MG; however, at this point it has been combined with power contributed by the engine series path (which is already accounted for via R1). To prevent double counting, the

second reference point is therefore called $R2_{REESS}$, and represents the portion of MG power that is attributable to the REESS.

63. TP1 is straightforward for this architecture. The power at R1 is determined from UN Regulation No. 85 results, and $R2_{REESS}$ is the measured REESS power multiplied by K1 (where K1 is the electrical conversion efficiency of the total power flow through Inv1 and MG). System power is the sum of R1 and $R2_{REESS}$.

64. TP2 is not as straightforward here. TP2 relies on a measure of total power at the axle shafts or wheel hubs, to which it seeks to apply a K2 efficiency factor to account for gearbox losses. But here, the power has arrived via two different paths from the engine, and a third path from the REESS, all of which have experienced different conversion efficiency. The combined power measurement at the axle does not identify the share of power along each path, so there is not enough information to reconstruct the power at R1 and $R2_{REESS}$ even if the conversion efficiency of each path is known.

65. Another option might be to compute $(R1+R2_{REESS})$ rather than each individually. This would require a "net" K2 factor that accounts for the total losses along all three paths. If all three paths had the same conversion efficiency, it would not be necessary to know the power along each path. But that is not the case here. While the manufacturer might be able to experimentally determine a "net" K2, it would not be possible to verify using the data that is collected by TP2. If the K2 factor were to represent anything other than this "net" factor, such as for example just the efficiency of the mechanical direct drive path, then it would not be reconstructing the power at either of the designated reference points.

66. This is another way of saying that the original versions of TP1 and TP2, when applied to a power split hybrid, each determine the power at slightly different reference points. When considered individually, either of the results might be reasonable as a system power rating. However, they cannot be expected to be the same if they refer to different reference points.

67. This situation is seen more clearly in Figure 10, for a pure series hybrid. As before, the reference points are where mechanical power is first produced, at R1 and $R2_{REESS}$. TP1 would determine the mechanical power from the engine (at R1) and the REESS contribution at motor MG (at $R2_{REESS}$). In contrast, TP2 would measure the power at the axle shafts and apply a K2 factor to account for losses in the gearbox and differential, thereby reaching a different reference point (here called $R2_{TOT}$) and reporting that as the system power. The power at $R2_{TOT}$ is bound to be different than at $(R1 + R2_{REESS})$. Further, R_{TOT} is inconsistent as a reference point because it is not a point where mechanical power is first produced.

Figure 10
Inconsistent reference points for TP1 and TP2 for pure series HEV

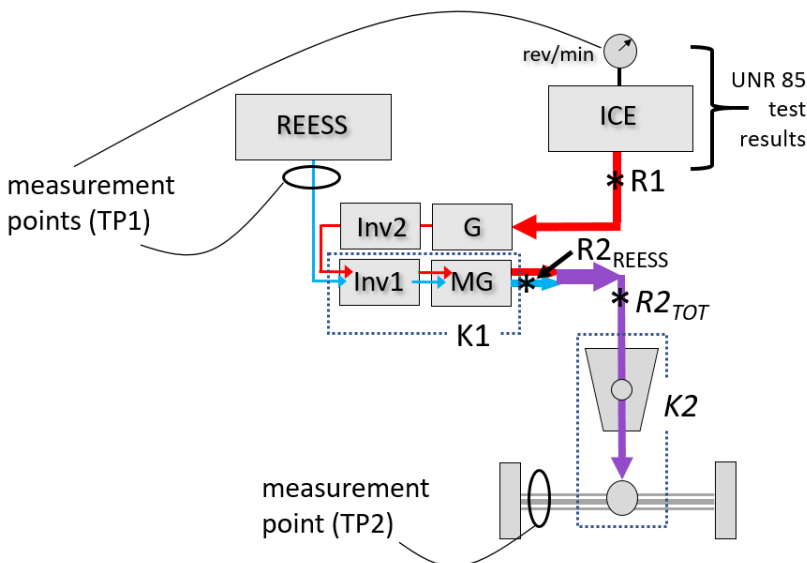

Note: measurement point for TP2 represents both axle shafts.

68. Further, as a side effect, here the power measured by TP2 at $R2_{TOT}$ will always be lower than for TP1, because the power at $R2_{TOT}$ has been reduced by losses in the electrical conversion path ($G+Inv2+Inv1+MG$), while TP1 considers them to be part of the allowable transmission losses.

69. Even when the reference points are harmonized, some powertrain architectures may pose special challenges to one or the other TP.

70. As shown in Figure 11, TP1 measures power out of the REESS, but does not account for how this power is divided downstream, between the two parallel inverter/motors $Inv1/MG1$ and $Inv2/MG2$. This means that the $K1$ factor must account for the combined losses in both inverter/motor combinations. Although the manufacturer might be able to experimentally determine and provide such a factor, it could not be independently verified from efficiency data without measuring the individual power flows.

71. Rather than measuring the REESS power, it would be more effective to measure the power into each inverter, and apply a separate $K1$ factor for each inverter/motor combination. In this case each $K1$ factor could be independently verified because the power flows are known.

72. In contrast, TP2 does not have a difficulty determining the sum ($R1+R2$) from the measured power at the axle, given an accurate $K2$ factor.

Figure 11

Parallel P2 hybrid with two motors, more difficult for TP1

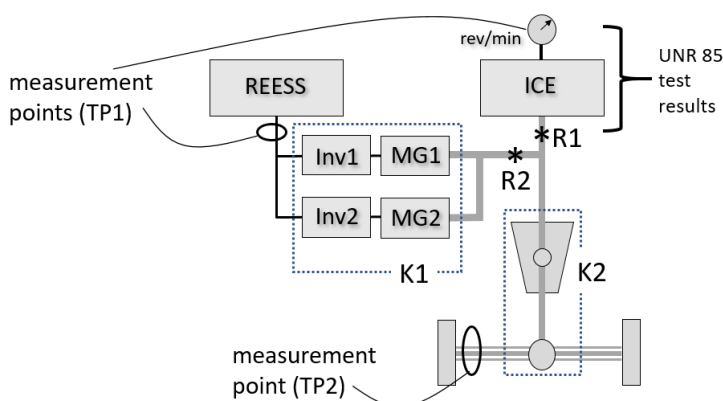

Note: measurement point for TP2 represents both axle shafts.

73. Figure 12 shows an example HEV with two powered axles. Here a four-wheel-drive dynamometer would be needed, and the power measured at each axle separately. The reference points on the first (right) axle are marked $R1$ and $R2$, and on the second (left) axle, $R3$. TP2 is straightforward for each axle (although it does require a unique $K2$ factor for each axle). TP1 can determine $R1$, $R2$, and $R3$ if the electrical measurement points include the inputs to each inverter ($Inv1$ and $Inv2$) and factors $K1_{(1)}$ and $K1_{(2)}$ are provided. Alternatively, TP1 can determine $R1$ and the sum ($R2+R3$) if the electrical measurement is at the REESS and the conversion efficiency of the two electrical paths can be combined or are the same.

Figure 12
Vehicle with two powered axles

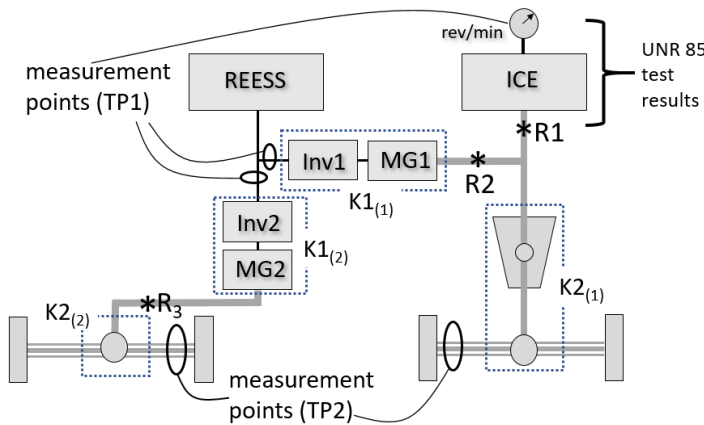

Note: measurement points for TP2 represent both axle shafts.

74. However, as shown in Figure 13, a small change to the configuration makes it very difficult to apply TP2. Here MG2 might represent a pair of wheel hub motor(s) which now contribute to powering the first axle. The power flow from the wheel hub motors at R3 is likely to experience a very high efficiency $K_{2(2)}$, while those entering the gearbox/differential from $(R1+R2)$ experience a probably lower efficiency $K_{2(1)}$. Because TP2 measures only the combined power, at the axle, it is not possible to apply both K factors to the portion they represent.

Figure 13
Configuration with difficulty for TP2

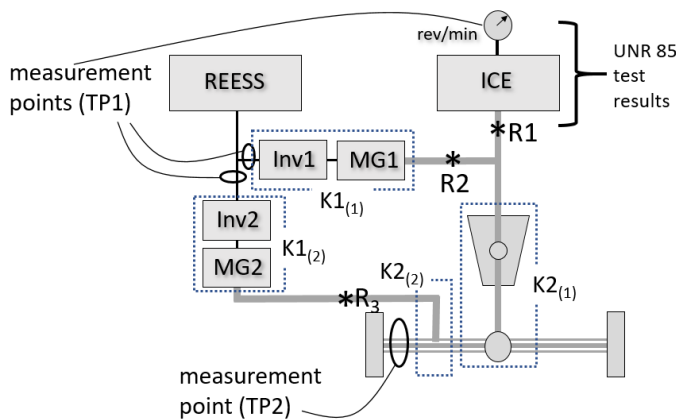

Note: measurement point for option 2 represents both axle shafts.

75. The applicability of TP1 and TP2 can depend not only on the physical configuration of the powertrain, but also on the selected driving mode. Figure 14 and Figure 15 show two high-power modes of the Generation 2 Chevy Volt powertrain, one for a pure electric charge-depleting (CD) mode and another for a blended charge-sustaining (CS) mode.

76. In CD mode (Figure 14), both TP1 and TP2 can be performed (with certain assumptions). TP1 can determine both $R1$ and $R2$, assuming that the power into each inverter is measured, or the sum $(R1+R2)$ if power from the REESS is measured and the conversion efficiency of both electrical conversion paths is the same and can thus be combined. TP2 can determine the sum $(R1+R2)$ from the power measured at the axle, assuming that the efficiency of each sun-to-planet (S, P) gear path is the same.

Figure 14
Volt Gen 2 charge-depleting Mode 2 (CD2)

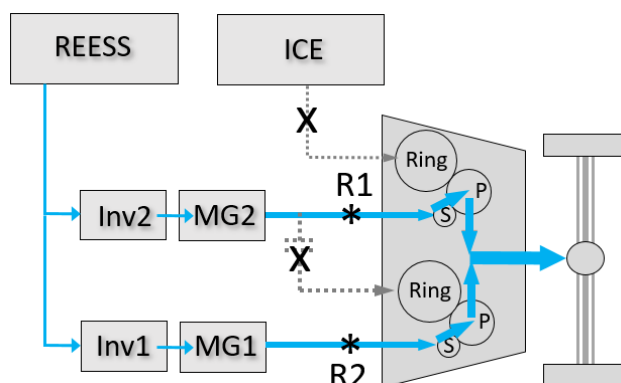

77. However, in CS mode (Figure 15), the power flow paths are different. TP1 can still determine R1 and R2 from engine and REESS measurements. But in order for TP2 to determine the sum $(R1+R2)$ as before, the efficiency of the Ring-to-planet and Sun-to-planet gear paths must be similar enough to be combined. Otherwise, the relative power contributed by the engine and the motor would be required, and it is not collected.

Figure 15
Volt Gen 2 charge sustaining mode 2 (CS2)

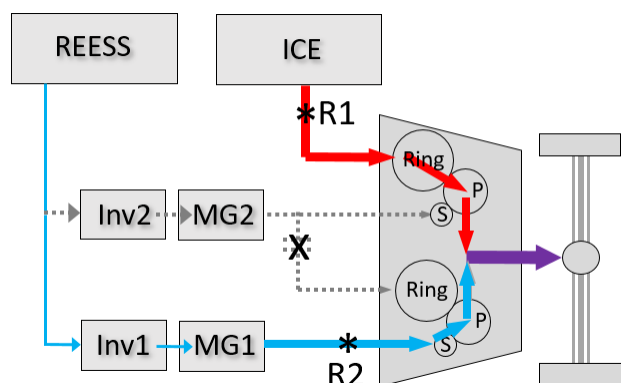

78. At the 30th IWG on EVE meeting, the IWG requested that experts from VDA (German Association of the Automotive Industry) who were involved with development of the ISO procedure provide additional input on the observed differences between the results of TP1 and TP2. VDA delivered a presentation at the 31st IWG on EVE addressing this topic and provided recommendations for the second phase of validation testing.

79. The VDA experts acknowledged that some of the deviation could be the result of fixed, default K1 and K2 factors, but felt that it was also important to verify that the measurement requirements and accuracies described in ISO 20762 are followed.

80. VDA also stated that TP1 and TP2 can be expected to give the same result for parallel hybrids, which is consistent with the discussion in the previous paragraphs.

81. For pure series or mixed (power split) hybrids, VDA stated that TP1 will always give a higher result than TP2 because TP1 does not account for electrical conversion losses in the series portion. This observation has now been explained by the difference in the reference points implied by TP1 and TP2 for power split and pure series hybrids, as discussed in the previous paragraphs. Defining the reference points as depicted in Figure 9 addresses this concern, and means that TP2 becomes not applicable to this powertrain.

7. Reconciling TP1 and TP2

82. The IWG on EVE recognized that the need to reconcile TP1 and TP2 was a significant outstanding issue for the completion of the GTR. At the 30th meeting of the IWG on EVE in Stockholm, the IWG considered several options for completing the GTR.

83. One possibility was to accept the difference between TP1 and TP2, and add interpretive text to the GTR to help users understand the difference. This would maintain the flexibility of the procedure, minimize divergence from ISO 20762, and reduce the likelihood that the difference could be misunderstood or deliberately misused. This option found little support.

84. Another possibility was to eliminate the difference by modifying the GTR to define only a single possible result, rather than two. This might be done by any of:

- (a) Including only TP1 or TP2 in the GTR;
- (b) Requiring both TP1 and TP2, and reporting the average, the lower, or the higher of the two;
- (c) Retaining the nominal choice of TP1 or TP2, but validating the result by performing the other TP as a consistency check;
- (d) Specifying TP1 for some HEV architectures and TP2 for others.

85. (a) The IWG was reluctant to eliminate either TP1 or TP2 entirely, due in part to the flexibility it affords, and preferences among members for one or the other procedure.

86. (b, c) The IWG was reluctant to require both TPs to be performed because this would increase the test burden. Also, it was noted that the best choice among an average, lower, or higher of the two results would depend on the intended purpose of the measure. For downscaling and classification under WLTP, selecting the higher figure might be preferable because it would prevent excessive downscaling. But for customer information, the lower figure might be preferable to prevent exaggerating the available power. It was unclear if there was a valid technical justification for selecting either figure, or an average of the two, when it remained uncertain which result is most accurate for a given vehicle.

87. (d) The IWG remained open to the possibility of assigning TP1 and TP2 to specific powertrain types, given a clear technical justification.

88. A final possibility was to modify the procedure to minimize the difference between TP1 and TP2 as much as possible.

89. Because the problem is essentially one of physics, it should be possible to define TP1 and TP2 so that they deliver comparable results in all cases, if the following is true: (a) the power flows in the vehicle are correctly understood, (b) the reference points are correctly identified and consistent under both TP1 and TP2, and (c) the measurements and K factors are sufficiently accurate to estimate the power at the reference points.

90. The question is to what degree the procedures for TP1 and TP2 can provide for this outcome while remaining practical to implement. For example, if successfully applying TP1 sometimes requires instrumentation of several inverter inputs rather than only the REESS output, or if successfully applying TP2 requires knowledge of relative power flows that are not measurable at the axle, the instrumentation burden may become prohibitive.

91. At the 30th and 31st IWG on EVE meetings it was generally agreed that the difference between TP1 and TP2 should be reduced as much as possible by modifying the procedures, and that limiting certain architectures to TP1 or TP2 could also be considered. Several proposed modifications were identified to be evaluated in a second phase of validation testing.

8. Modifications to the procedure

92. The IWG reached consensus on several proposed modifications to reduce the difference between TP1 and TP2:

(a) The option to use default K factors was replaced with a requirement that the manufacturer provide accurate and verifiable K factors specific to the vehicle under test.

(b) The option to conduct TP2 using chassis dynamometer roller data was removed, in favor of axle or wheel hub instrumentation for torque and speed, or a hub dynamometer.

(c) The procedure was clarified to require that current and voltage, if obtained from onboard systems, must be shown to be accurate (TP1).

93. The drafting group also proposed several changes to be trialed in the second validation phase:

(a) To reduce the possibility of variation, five repetitions of the power test are conducted and an average taken of the last four results (see paragraph 6.8.7.).

(b) Applicability guidelines were added to determine the permissible application of TP1 and TP2 based on aspects of the power flows between the measurement points and the reference points, and any need for additional instrumentation to enable one or the other TP (see paragraph 6.1.3.).

(c) A requirement was added for the manufacturer to document the flow of propulsion power through the powertrain of the vehicle during the maximum power condition, the proposed measurement points and reference points, and applicable K factors for TP1 or TP2 (see paragraph 6.1.1.1.).

(d) The term "reference point" was introduced and defined. Guidelines for identifying reference points are provided in Annex 1.

94. The new requirement that K factors be furnished by the manufacturer means that it must be possible for the manufacturer to determine the relevant K factor, and for a third party to verify it by a standard method.

95. The IWG considered that for TP1, test standards exist for the measurement of inverter and motor efficiency (K1), which could be used by the manufacturer to derive the K1 factor as well as by a third party to verify it. However, no similar test standard exists for gearbox efficiency (K2).

96. VDA was asked to provide a recommendation for a standard method for determining K2 for TP2. VDA recommended that any of various engineering methods could be employed, based on measurement of power in and power out on a test bench, and dividing output power by input power.

97. The IWG also considered a proposal that a K2 factor might be determined (or verified) by performing TP1 using a known accurate K1 factor, and then solving for K2 by setting the result of TP1 equal to the result of TP2. A similar tactic might also be usable for internal validation of a test result. This approach was to be further evaluated with data from the second phase of validation.

9. Second phase of validation testing

98. The test laboratories were requested to implement a second phase of validation testing, with the following changes to the test program:

(a) Conduct TP2 with torque and speed data from torque and speed sensors rather than dynamometer roller data.

(b) Conduct TP1 with current and voltage data collected from current and voltage instrumentation, in addition to onboard data.

(c) If more than one electrical power path is present downstream of the battery, then instrument the inputs to each inverter (if possible).

(d) Seek measurements of electrical power to non-propulsion accessories.

(e) Improve precision of wheel speed and dynamometer roller speed to identify presence of wheel slippage.

(f) If significant wheel slippage is observed, add weight to the vehicle to eliminate it, particularly if slippage might affect the shifting or other behavior of the vehicle.

99. In most cases, K factors were not expected to be available. Outside of a type approval or certification context, manufacturers are unlikely to have suitable data already prepared and little incentive to produce it. Even if K factors were provided, their usefulness in validating the procedure would be limited unless they could be independently verified (which was not within the scope of the program). Instead, the results were to be evaluated by considering the ability for reasonable K factors to make the results of each TP consistent with each other.

100. For the second phase of validation, ECCC tested: a 2018 BMW 530e (OVC-HEV), a 2016 Chevrolet Volt (OVC-HEV), a 2018 Toyota Prius Prime (OVC-HEV), and a 2009 Saturn Vue (mild BAS NOVC-HEV). JRC expressed an intention of testing two additional vehicles, and as of Autumn 2019 were continuing efforts to procure suitable vehicles and provide them with necessary instrumentation. US EPA had intended to test two additional vehicles, but damage to one of the vehicles, and an unexpected difficulty with the funding mechanism for contract work necessary to instrument the vehicles, made it impossible for EPA to participate in the second phase.

101. Results of the second phase began to become available in late 2019 and continued to be produced through March 2020. Results of this testing were presented and discussed in various EVE IWG meetings. ^[M2]

102. JRC provided test results for hub dyno testing and is progressing to provide results of wheel torque measurements on the same vehicle.

103. Throughout the test program, ECCC encountered difficulty obtaining UN Regulation No. 85 engine test results applicable to the vehicles tested. UN Regulation No. 85 results were obtained for the Toyota Prius Prime in January 2020, and for the European version of the BMW 530e in February 2020 (however, the vehicle tested was a North America vehicle for which the engine has a different torque specification). Because the Chevy Volt and the Saturn Vue are not EU-spec vehicles, UN Regulation No85 data was not available for these vehicles. For these reasons, TP1 could not be performed for these in exactly the manner prescribed.

104. As for TP2 results, ECCC found that the torque and speed measurement devices gave inconsistent results and in some cases malfunctioned. There is significant doubt as to whether the TP2 results are valid due to these difficulties.

105. Although a direct comparison between TP1 and TP2 was therefore not possible in many cases, the second phase of validation revealed valuable recommendations regarding the practicability of the procedure and recommendations for improvement.

106. Additionally, late results from JRC testing with a hub dynamometer have confirmed good agreement between TP1 and TP2 for a P2 hybrid configuration. Analysis of the data will continue to further validate this conclusion and for consideration in the development of future versions of this GTR.

C. Technical rationale and justification

Section C.1 describes the technical justification for the major specific differences between the procedure described in this GTR and the ISO 20762 procedure on which it was based.

Section C.2 provides additional discussion of the basis upon which the IWG on EVE recommends the procedure as a whole.

1. Primary differences between ISO 20762 and this GTR

(a) *Some measurement accuracies aligned with UN GTR No. 15*

107. A primary anticipated use for the test procedure is for determining a system power for the purpose of classification and downscaling under the WLTP test procedure defined in UN GTR No. 15. In a few cases where requirements stated under ISO 20762 varied from

UN GTR No. 15 they were aligned with UN GTR No. 15, as can be seen in paragraph 5.2. of this GTR and summarized in Table 1 below.

Table 1
Differences in required measurement accuracies

<i>Measurement item</i>	<i>ISO 20762</i>	<i>UN GTR No. 15 and this GTR</i>
Electrical voltage	±0.5 %	±0.3 % FSD or ±1 % of reading
Electrical current	±0.5 %	±0.3 % FSD or ±1 % of reading
Room temperature	±2 °C	±1 °C
Dynamometer speed	±0.5 km/h or ±1 %, whichever is greater	±0.2 km/h

(b) *Manufacturer to provide verifiable K factor(s)*

108. ISO 20762 allows for K factors to be provided by the manufacturer. It also provides default K factors that could be used as needed. The IWG on EVE noted that no fixed default K factor could be expected to be equally accurate for all vehicles, and so the use of default factors could contribute to variation between TP1 and TP2.

109. Unlike ISO 20762, this GTR is likely to be applied in the context of type approval or certification. In this context, it is likely that there will be sufficient manufacturer cooperation to prevent the need to assume a default K factor.

110. This GTR therefore requires the manufacturer to provide verifiable K factor(s) in all cases, as described at paragraph 6.1.1.2. Determination and verification of the provided K factor(s) can be performed through applicable test standards or other methods as described in paragraph 6.1.1.2.

(c) *TP2 to utilize torque and speed sensors or hub dynamometer*

111. ISO 20762 specified that measurement of torque and speed for TP2 may be acquired by use of torque and speed sensors attached to the axle shafts or wheel hubs, or by dynamometer measurements of speed and torque delivered to the dynamometer rollers. In the latter case, losses in the tires are to be accounted for. A specific method for determining the losses is not provided.

112. The IWG found that accounting for tire losses may introduce uncertainties specific to TP2. Accounting for rolling resistance requires that the rolling resistance coefficient (RRC) and the normal force on the tires both be known. RRC is not always known with high accuracy. When installed on a dynamometer, the normal force may be uncertain due to the effect of the tie down method (usually tensioned straps or chains, or rigid restraints). Tire slippage under maximum power may be difficult to eliminate, and can add losses that are difficult to quantify.

113. The GTR therefore removes the option for dynamometer roller measurements for TP2, and adds a new option to use a hub dynamometer on each powered axle as described at paragraph 6.1.2.2. of this GTR.

(d) *TP1 to include measurement of fuel flow rate*

114. ISO 20762 required measurement of intake manifold pressure for verification of engine power by reference to ISO 1585 test conditions. Measurement of fuel flow rate is only required if the confirmation of air fuel ratio according to ISO 1585 is necessary.

115. Experts in the IWG indicated that intake manifold pressure may be insufficient to verify ISO 1585 test conditions especially considering variable atmospheric conditions. Fuel flow rate provides a more precise and additional check.

116. The GTR therefore requires collection of fuel flow rate for TP1 in all cases. To minimize burden, fuel flow rate may be collected from on-board data if its accuracy is shown to the responsible authority.

(e) *TP1 recommended to measure power input at each inverter if REESS powers multiple inverters*

117. ISO 20762 specified that TP1 be performed with measurement of current and voltage at the REESS.

118. The IWG found that this may introduce uncertainties specific to TP1, for electrified powertrains in which the current from the REESS is subsequently routed to more than one propulsion energy converter (i.e. more than one inverter/motor combination) that are deemed likely to experience significantly different electrical conversion efficiencies.

119. For powertrains where the REESS current is routed to more than one propulsion energy converter, this GTR recommends that the input to each inverter be instrumented in addition to the REESS output, unless it is possible to determine net efficiency of the combination, or the efficiencies are the same, as described in paragraph 6.1.3.1. of this GTR. Use of on-board data may be another alternative as allowed in paragraph 6.1.2.

(f) *Repetition and averaging*

120. ISO 20762 does not include a requirement for repetition or averaging of multiple tests. In validation testing, some variation was observed between sequential tests. Korea recommended performing several tests and disregarding the first test result. Subsequent testing confirmed that this practice reduces the variation. The GTR now specifies that five repetitions be conducted and the result be based on an average of the last four repetitions.

121. The GTR also places a limit on the variability of the four averaged measurements, at within ± 5 percent of the mean. The variation must be recorded and if it is exceeded, the tests should be performed again, and if the variation cannot be reduced, the result is subject to approval by the responsible authority.

(g) *Establishment of the "reference point" concept to assure comparable and equivalent results for various HEV architectures*

122. The IWG found that the clear identification of reference points for various HEV architectures, and the use of the same reference points for both TP1 and TP2, are important to the expectation that TP1 and TP2 should both deliver a highly similar result. This GTR establishes reference points for common HEV architectures (see Annex 1 of this GTR) and provides a clear definition of "reference point" (see paragraph 3.5.) to assist with the identification of valid reference points for other architectures.

(h) *Applicability of TP1 or TP2 determined by power flows*

123. ISO 20762 did not limit application of TP1 or TP2 to specific powertrain types.

124. The IWG found that the specific flow of power through different electrified powertrain architectures can pose uncertainties for the equitable application of TP1 or TP2 using the specified reference points and measurement points.

125. The GTR therefore includes a set of applicability rules to determine the applicability of TP1 and TP2 based on characteristics of power flow through the powertrain as described in paragraph 6.1.3. of this GTR.

(i) *Manufacturer to provide hybrid power flow description*

126. The IWG found that some electrified powertrains support complex power flows. The specific flow of power that takes place under the maximum power condition is not always clear. This GTR adds a specific requirement for the manufacturer to provide a hybrid power flow description as described in paragraph 6.1.1.1. of this GTR. The description shall also specify recommended measurement points, reference points, and K factor(s), where applicable. The description is intended to provide the authority with concrete information

that may be used to determine the applicability of TP1 and TP2 and to assist the authority or third parties with validation and verification.

(j) *All-wheel drive vehicles to account for each axle independently*

127. ISO 20762 did not distinguish between differently powered axles. The GTR adds a specific provision that if a vehicle has two powered axles, each axle shall be tested independently and simultaneously on a 4wd chassis dynamometer or two hub dynamometers, and each may apply a different TP if desired (see text at paragraph 6.1.).

(k) *Addition of internal validation criteria*

128. This GTR introduces a simple mathematical test to reject a result that is inconsistent with the effect of losses in the drivetrain (see paragraph 6.10.). An implied drivetrain efficiency is computed by dividing the power measured at the dynamometer by the sustained power result. Due to drivetrain losses, the quotient should be less than 1. The addition of this validation step results in a new requirement to collect the power delivered by the vehicle to the dynamometer as described at the end of paragraph 6.1.2.

(l) *New terms defined*

129. Definitions have been added for several new terms related to system power determination (see paragraph 3.5.).

(m) *Clarification of gear shifting*

130. ISO 20762 did not address the possibility of automatic gear shifting that might occur during the 10-second window of the power test, or the permissibility of manual gear shifting if the gearbox is ordinarily automatically shifted. Text has been added in paragraphs 6.8.6. and 6.9.1. to clarify these issues.

(n) *Permissibility of validated onboard data for all measurements*

131. UN GTR No. 15 allows for the use of on-board data in place of REESS measurements for current and voltage, if the accuracy of the data is demonstrated to the responsible authority. It was noted that such a provision in this GTR could provide an alternative to potentially difficult or impractical instrumentation of inverter inputs or other electrical components under TP1. It was also noted that the added requirement to physically measure the fuel flow rate could be burdensome, and that the use of validated on-board data could also reduce the instrumentation burden for other parameters needed for the power calculation. Text was therefore added in paragraph 6.1.2. of this GTR to generally allow use of on-board data when available, subject to demonstration to the responsible authority that the use of this data meets the accuracy and frequency requirements under paragraph 5.2.

(o) *Updated equations for calculating system power*

132. The equations for calculating system power rating under TP1 and TP2 in paragraph 6.9. have been revised to clarify that the system power rating is the summation of the power calculated at all of the reference points that are applicable to the vehicle powertrain architecture.

2. Recommendation of procedure

133. Both the first and second phases of the validation program provided a wealth of information relating to the practicability and effectiveness of the draft procedure. The opportunity to implement the evolving procedure at several laboratories helped to identify ambiguities in the procedure, as well as evaluate the procedure for the ability to produce an effective characterization of system power in a reliable manner.

134. The differences between the results of TP1 and TP2 that were encountered in the first phase of validation also led to a careful examination of the nature of the problem that the procedure seeks to solve, and the theoretical and physical requirements for a valid solution. This led to the development of the reference point concept, which, when integrated with the

procedure, provided (a) a clear technical basis for judging the applicability of TP1 or TP2 to various powertrain architectures, and (b) a strong theoretical basis for the expectation that TP1 and TP2 should yield similar results for powertrains to which both are applicable.

135. Ideally, validation of the procedure would be founded on strong evidence that TP1 and TP2 deliver closely similar results. The latest JRC results from the hub dynamometer tests confirmed a good agreement for a P2 parallel hybrid. However, the validation program was able to produce only limited additional data that would allow a direct comparison between the results of TP1 and TP2 for the same vehicle.

136. One reason is that for some of the powertrain architectures, either TP1 or TP2 is no longer applicable under the revised procedure. These vehicles cannot provide a comparison between TP1 and TP2 because only one is applicable.

137. Another reason is that it was not possible to authentically reproduce all of the aspects of a type approval situation in the validation program. In some cases this limited the ability to perform both TP1 and TP2 in the prescribed manner. For example, in a type approval situation, the manufacturer would have prepared in advance all of the information that is now required for conducting the revised procedure, often relying on proprietary information that was not available to the validation program. This information, such as K factors for TP1 or TP2, hybrid power flow descriptions, and in some cases UN Regulation No. 85 engine test data, were not available, partly because some were new requirements that did not allow the necessary lead time, and partly because of limited motivation for manufacturers of the selected vehicles to provide this proprietary information.

138. Aside from limited opportunity to directly compare TP1 and TP2, there are several persuasive reasons to have good confidence in the ability of the revised procedure to deliver valid results.

139. In the revised procedure, it is now assured that both TP1 and TP2 measure power at the same reference points. This eliminates a cause of some previously identified differences, which were related to the implicit use of sometimes inconsistent reference points in the earlier version of the procedure.

140. The revised procedure also makes it clear whether or not a given TP is applicable to a given vehicle, preventing the possibility of applying a TP for which the powertrain architecture cannot support its use, and leading to the delivery of only a single result.

141. Additionally, the validation program provided additional evidence that the maximum power of the vehicles tested can be reliably commanded by the fixed-speed dynamometer method.

142. The primary remaining potential source of error between the two TPs would be measurement error. Requirements for measurement accuracy and frequency are clearly identified in the procedure, and align with similar requirements in ISO 20762 and UN GTR No. 15. If the type approval authority conducts the procedure with care, the remaining potential for error should be small.

3. Future development of the GTR

143. At this time, this GTR specifies a reference method but not a candidate method. A candidate method, which would not require dynamometer testing but instead would be based on the results of component tests, would potentially allow a vehicle power rating to be determined at a lower expense. Future development and validation of a candidate method remains a possibility for future work.

D. Technical feasibility, anticipated costs and benefits

144. The specification of a test procedure for power determination will remove significant uncertainty that manufacturers now face in communicating the power level of electrified vehicles both to the public and to regulating authorities, and resolves the question of how to determine a system power rating for electrified vehicles for use with WLTP.

145. Initially the adoption of the procedure may bear some costs for vehicle manufacturers, technical services and authorities, at least considered on a local scale, since some test equipment and procedures may have to be upgraded. However, these costs should be limited since such upgrades are done regularly as adaptations to technical progress. Related costs would have to be quantified on a regional level since they largely depend on the local conditions.

II. Text of the GTR

1. Purpose

This Global Technical Regulation (UN GTR) provides a worldwide harmonized method to determine a system power rating for electrified light-duty vehicles that is comparable to traditional measures of system power applicable to conventional vehicles.

2. Scope and application

2.1. This UN GTR applies to vehicles that meet all of the following criteria (a) through (c):

(a) Are hybrid electric vehicles, or are pure electric vehicles that have more than one propulsion energy converter;

and

(b) Are classified in category 1-1, or are classified in category 1-2 or 2 and have a technically permissible maximum laden mass not exceeding 3,500 kg;

and

(c) If a hybrid electric vehicle, at least one electric machine contributes to propulsion of the vehicle under the maximum power condition.

2.2. This UN GTR does not apply to fuel cell vehicles.

2.3. When determined according to the requirements of this UN GTR, the resulting vehicle system power rating may be considered as comparable to the power rating traditionally assigned to conventional vehicles, which is the power rating of the internal combustion engine.

2.4. The following document(s) are referenced in such a way that some or all of their content constitutes requirements of this document. The latest edition of the referenced document(s) (including any amendments) applies:

ISO 1585:1992, Road vehicles – engine test code – Net power

UN Regulation No. 85 — Uniform provisions concerning the approval of internal combustion engines or electric drive trains intended for the propulsion of motor vehicles of categories M and N with regard to the measurement of net power and the maximum 30 minutes power of electric drive trains

3. Definitions

The following definitions shall apply in this Global Technical Regulation. For any terms not herein defined, the definition set out in UN GTR No. 15 shall apply.

3.1. Road load and dynamometer setting

3.1.1. "Technically permissible maximum laden mass" means the maximum mass allocated to a vehicle on the basis of its construction features and its design performances.

3.1.2. "Fixed speed mode" means the operating mode of the dynamometer in which the dynamometer absorbs the power output of the vehicle so as to maintain the vehicle at a fixed dynamometer speed.

- 3.1.3. "Road load mode" means the operating mode of the dynamometer in which the dynamometer exerts on the vehicle a force equivalent to the force exerted on the vehicle while driving on a road.
- 3.2. Powertrain
- 3.2.1. "Powertrain" means the total combination in a vehicle of propulsion energy storage system(s), propulsion energy converter(s) and the drivetrain(s) providing the mechanical energy at the wheels for the purpose of vehicle propulsion, plus peripheral devices.
- 3.2.2. "~~Peripheral devices~~" means ~~energy consuming, converting, storing or supplying devices, where the energy is not primarily used for the purpose of vehicle propulsion, or other parts, systems and control units, which are essential to the operation of the powertrain.~~ any energy consuming, converting, storing or supplying devices, where the energy is not directly or indirectly used for the purpose of vehicle propulsion but which are essential to the operation of the powertrain and are therefore considered to be part of the powertrain.
- 3.2.3. "Auxiliary devices" means energy consuming, converting, storing or supplying non-peripheral devices or systems which are installed in the vehicle for purposes other than the propulsion of the vehicle and are therefore not considered to be part of the powertrain.
- 3.2.4. "Drivetrain" means the connected elements of the powertrain for transmission of the mechanical energy between the propulsion energy converter(s) and the wheels.
- 3.3. Electrified vehicles
- 3.3.1. "Energy converter" means a system where the form of energy output is different from the form of energy input.
- 3.3.2. "Propulsion energy converter" means an energy converter of the powertrain which is not a peripheral device whose output energy is used directly or indirectly for the purpose of vehicle propulsion.
- 3.3.3. "Charge-depleting operating condition" means an operating condition in which the energy stored in the REESS may fluctuate but decreases on average while the vehicle is driven until transition to charge-sustaining operation.
- 3.3.4. "Charge-sustaining operating condition" means an operating condition in which the energy stored in the REESS may fluctuate but, on average, is maintained at a neutral charging balance level while the vehicle is driven.
- 3.3.5. "Category of propulsion energy converter" means (i) an internal combustion engine, or (ii) an electric machine, or (iii) a fuel cell.
- 3.3.6. "Energy storage system" means a system which stores energy and releases it in the same form as was input.
- 3.3.7. "Propulsion energy storage system" means an energy storage system of the powertrain which is not a peripheral device and whose output energy is used directly or indirectly for the purpose of vehicle propulsion.
- 3.3.8. "Category of propulsion energy storage system" means (i) a fuel storage system, or (ii) a rechargeable electric energy storage system, or (iii) a rechargeable mechanical energy storage system.
- 3.3.9. "Form of energy" means (i) electrical energy, or (ii) mechanical energy, or (iii) chemical energy (including fuels).
- 3.3.10. "Fuel storage system" means a propulsion energy storage system that stores chemical energy as liquid or gaseous fuel.
- 3.3.11. "Electric machine" means an energy converter transforming between electrical and mechanical energy.

- 3.3.12. "*Off-vehicle charging hybrid electric vehicle*" (OVC-HEV) means a hybrid electric vehicle that can be charged from an external source.
- 3.3.13. "*Not off-vehicle charging hybrid electric vehicle*" (NOVC-HEV) means a hybrid electric vehicle that cannot be charged from an external source.
- 3.3.14. "*Hybrid vehicle*" means a vehicle equipped with a powertrain containing at least two different categories of propulsion energy converters and at least two different categories of propulsion energy storage systems.
- 3.3.15. "*Hybrid electric vehicle*" means a hybrid vehicle equipped with a powertrain containing at least one electric motor or electric motor-generator and at least one internal combustion engine as propulsion energy converter.
- 3.3.16. "*Pure electric vehicle*" (PEV) means a vehicle equipped with a powertrain containing exclusively electric machines as propulsion energy converters and exclusively rechargeable electric energy storage systems as propulsion energy storage systems.
- 3.3.17. "*Rechargeable electrical energy storage system*" (REESS) means a propulsion energy storage system that stores electrical energy and which is rechargeable. A battery whose primary use is to supply power for starting the engine and/or lighting and/or other vehicle auxiliaries systems is not considered as a REESS. The REESS may include the necessary ancillary systems for physical support, thermal management, electronic controls and casing.
- 3.3.18. "*State of charge*" (SOC) means the available electrical charge in a REESS expressed as a percentage of its rated capacity.
- 3.4. General
- 3.4.1. "*Driver-selectable mode*" means a distinct driver-selectable condition which could affect emissions, or fuel and/or energy consumption, or maximum system power output.
- 3.5. System power determination
- 3.5.1. "*Test procedure 1*" (TP1) means a test procedure, defined herein, for determining a vehicle system power rating via measured electrical power and determined ICE power.
- 3.5.2. "*Test procedure 2*" (TP2) means a test procedure, defined herein, for determining a vehicle system power rating via measured torque and speed at the axles or wheel hubs.
- 3.5.3. "*Power determination reference point*" (or simply "reference point") means a point in the mechanical power flow path of a powertrain where any portion of the mechanical energy that drives the wheels under the maximum power condition is first produced as mechanical energy by a propulsion energy converter from a propulsion energy storage system.
- 3.5.4. "*Power-rating mode*" means the driver-selectable mode (if any) for which a vehicle system power rating is desired.
- 3.5.5. "*Speed of maximum power*" means the fixed speed setting of the dynamometer at which a maximum accelerator  command, given for a period of at least ten seconds while the vehicle is in power-rating mode, delivers the greatest peak power to the dynamometer.
- 3.5.6. "*Maximum power condition*" means the condition in which the vehicle is operating on a dynamometer, the vehicle is in power-rating mode, the dynamometer is operating in fixed speed mode set to the speed of maximum power, and the maximum accelerator command is given for a period of at least ten seconds.
- 3.5.7. "*Vehicle system power rating*" means the total power transmitted through all of the power determination reference point(s) as determined by TP1 or TP2.

- 3.5.8. "Mechanical energy path" means a distinct parallel path within a drivetrain that conducts a portion of the total mechanical energy passing through the drivetrain.
- 3.5.9. ~~[[Reserved]]~~
- 3.5.10. ~~[[Reserved]]~~
- ~~3.5.911.~~ "Major maintenance" means the adjustment, repair or replacement of a component or module that could affect the accuracy of a measurement.
- 3.6. System bench
- 3.6.1. "System bench" means a simulated vehicle powertrain on a test bench, which is a combination of the propulsion energy storage system(s), propulsion energy converter(s) and the drivetrain(s) providing the mechanical energy at the wheels for the purpose of vehicle propulsion, plus peripheral devices. A system bench may include simulators, defined as a virtual model that is a software reproduction of some-one or more of the powertrain elements.
- ~~3.6.2.~~ ~~"Simulators" means a virtual model that is a software reproduction of some of the powertrain elements. Simulators may be used as part of the system bench.~~
- ~~3.6.32.~~ "Peripheral devices" means supplying devices, where the energy is not primarily used for the purpose of vehicle propulsion, or other parts, systems and control units, which are essential to the operation of the powertrain. In addition, if the functions equivalent to the actual vehicle are satisfied, the equipment specifications may be substituted.

4. Abbreviations

General abbreviations

AWD	all-wheel drive
FSD	Full scale deflection
HEV	hybrid-electric vehicle
ICE	internal combustion engine
ICEV	internal combustion engine vehicle
ISO	International Organization for Standardization
REESS	rechargeable electric energy storage system
SOC	state of charge
UN	United Nations
TP1	Test procedure 1
TP2	Test procedure 2
OVC-HEV	Off-vehicle charging hybrid electric vehicle
NOVC-HEV	Not off-vehicle charging hybrid electric vehicle
PEV	Pure electric vehicle

5. Test conditions

- 5.1. Test instrumentation
- 5.1.1. Dynamometer

The power absorption capacity of the dynamometer in fixed speed control mode shall be sufficient for the maximum power of the vehicle. Due to the short duration of maximum power under the test procedure (approximately 10 seconds), a short duration power rating of the dynamometer may be applicable to this requirement with approval of the responsible authority.

5.1.2. Test room

The test room shall have a temperature set point of 25 °C. The tolerance of the actual value shall be within ± 5 °C. At the request of the manufacturer, the 25 °C temperature set point can be replaced by 23 °C. [MS20][M21][M22]

Atmospheric pressure in the test cell shall be between 80kPa and 110 kPa.

5.1.3. Cooling fan

A current of air of variable speed shall be blown towards the vehicle sufficient to maintain the proper system operating temperatures (see 6.8.1.). The set point of the linear velocity of the air at the blower outlet shall be equal to the corresponding dynamometer speed above measurement speeds of 5 km/h. The deviation of the linear velocity of the air at the blower outlet shall remain within ± 10 % of the corresponding measurement speed, up to the maximum speed of the blower. In the case of the system bench, the manufacturer should provide the recommended airflow velocity necessary to maintain proper system operating temperatures and system function, equivalent to vehicle use. Excessive cooling is prohibited. [RC23][M24]

5.1.4. Soak area

The soak area shall have a temperature set point of 25 °C. The tolerance of the actual value shall be within ± 5 °C. At the request of the manufacturer, 25 °C can be replaced by Type 1 soak area target temperature of 23 °C.

5.2. Measurement

5.2.1. Measurement items and accuracy

Measurement devices shall be of certified accuracy as shown in Table 2 traceable to an approved regional or international standard.

Table 2
Measurement items and required accuracy

<i>Item</i>	<i>Units</i>	<i>Accuracy</i>	<i>Remarks</i>
Engine speed	min ⁻¹	± 10 min ⁻¹ or $\pm 0.5\%$ of measured value, or from onboard engine speed signal	
Intake manifold pressure	Pa	± 2 %	
Atmospheric pressure	Pa	± 0.1 kPa, with a measurement frequency of at least 0.1 Hz, or from onboard atmospheric pressure signal	
Specific humidity	g H ₂ O/kg dry air	± 1 g H ₂ O/kg dry air	
Fuel flow rate	g/s	± 3 %, or from onboard fuel flow rate signal	

Item	Units	Accuracy	Remarks
Electrical voltage	V	± 0.3 % FSD or ± 1 % of reading	Whichever is greater. Resolution 0.1 V.
Electrical current	A	± 0.3 % FSD or ± 1 % of reading	Whichever is greater. Current integration frequency 20 Hz or more for external measurement. Resolution 0.1 A.
Room temperature	K	± 1 °C, with a measurement frequency of at least 0.1 Hz	
<u>[Chassis]</u> <u>Dynamometer</u> speed	km/h	The dynamometer speeds shall be controlled with an accuracy of ± 0.2 km/h or ± 0.1 % of full scale vehicle speed, whichever is greater.	
<u>[Chassis]</u> <u>Dynamometer</u> force	N	The accuracy of the force transducer shall be at least ± 10 N for all measured increments. This shall be verified upon initial installation, after major maintenance and within 370 days before testing.	
Time	s	± 100 ms; min. precision and resolution: 100 ms	
Axle/wheel rotational speed <u>[of</u> <u>hub dynamometer or</u> <u>system bench]</u>	rev/s	± 0.05 s ⁻¹ or ± 1 % <u>[of full scale</u> <u>rotational speed]</u> , whichever is greater	
Axle/wheel torque <u>[of hub dynamometer</u> <u>or system bench]</u>	Nm	± 6 Nm or ± 0.5 % <u>[of full scale torque.]</u> of the maximum measured total torque, whichever is greater, for the whole vehicle.	
Accelerator command	percent	As read from onboard accelerator command signal	

5.2.2. Measurement frequency

All the items in Table 2 of 5.2.1., unless specified otherwise in the table, shall be measured and recorded at a frequency equal to or greater than 10 Hz.

The items atmospheric pressure and room temperature shall be at least recorded as single measurement activity at start of vehicle operation (see 6.8.5.) and after end of vehicle running (see 6.8.8.).

6. Test procedure

6.1. General

The following test procedures determine a vehicle system power rating for a hybrid electric vehicle, or for a pure electric vehicle with more than one propulsion energy converter.

Two test procedures are described herein.

Test procedure 1 (TP1) is based on measured electrical power, estimated ICE power, and estimated electrical conversion efficiency.

Test procedure 2 (TP2) is based on measured torque and speed at the drive shaft(s) or wheel hub(s) and estimated mechanical conversion efficiency.

TP1 and TP2 are intended to be technically equivalent methods for determining a vehicle system power rating from available measurements. TP1 and TP2 are distinguished by the specific instrumentation, measurements, other inputs, and calculations necessary to determine the vehicle system power rating.

Each powered axle that provides propulsion under the maximum power condition shall be tested by chassis dynamometer or hub dynamometer [or system bench]. Vehicles that are powered by two powered axles under the maximum power condition shall be tested by four-wheel-drive chassis dynamometer, or each powered axle shall be tested simultaneously by hub dynamometer [or system bench]. ~~In the case of vehicles whose maximum power, in the judgment of the responsible authority, exceeds that of readily available dynamometers, it~~ It is permissible to use a system bench, which may include simulators, in place of a dynamometer. In that case, the facilities must be approved by the responsible authority according to Annex 3 for facilities approval. [MS2] [MS1] [MS2]

6.1.1. Required information

The manufacturer shall provide the following information required to conduct either test procedure.

6.1.1.1. Hybrid power flow description [RC35]

The manufacturer shall provide a hybrid power flow description sufficient to identify the energy flow paths and energy conversions by which propulsion is produced during the maximum power condition, beginning at each of the propulsion energy storage systems and proceeding to each powered axle. The description shall also indicate each non-propulsion auxiliary and peripheral device that is powered by the REESS under this condition, including DC/DC converter and high-voltage auxiliaries or peripherals.

The description shall also indicate the power determination reference points applicable to the vehicle (according to the guidelines in Annex 1 of this GTR), the measurement points according to TP1 or TP2, and the components to which applicable energy conversion factors (K factors) apply.

6.1.1.2. Energy conversion factors (K factors)

Where TP1 is to be performed, the manufacturer shall provide the electrical energy conversion efficiency (K1) between each electrical measurement point and corresponding reference point, applicable to the maximum power condition. In general, K1 factors represent output power of an electric machine (or a combination of electric machines where applicable) divided by input power to the inverter that powers the electric machine(s).

In determining or verifying a K1 factor, the electrical conversion efficiency of the inverter and electric machine or their combinations shall be determined by an applicable test standard such as ISO 21782, SAE J2907, or equivalent. The provided value is subject to verification by the responsible authority.

Where TP2 is to be performed, the manufacturer shall provide, for each powered axle, the mechanical energy conversion efficiency (K2) between each axle or wheel hub power measurement point and corresponding reference point(s), applicable to the maximum power condition. In general, K2 factors represent mechanical power output to the axle shafts or wheel hubs divided by mechanical power input to a gearbox or set of similar mechanical components by which the mechanical power is conducted from the applicable reference point(s).

In determining or verifying a K2 factor, the mechanical conversion efficiency of drivetrain components or their combinations shall be determined by dividing the measured output power by the measured input power. The provided value is subject to verification by the responsible authority.

6.1.1.3. Speed of maximum power

The speed of maximum power (as defined in 3.5) shall be determined by the procedure specified in Annex 2, either by the manufacturer or by the responsible authority.

6.1.1.4. Other information

The manufacturer shall specify the normal operating range for each operational metric listed in 6.8.1.

Regarding any dynamometer operation mode (see 6.7), the manufacturer shall provide a list of the deactivated devices and justification for the deactivation.

6.1.2. Required measurements

The test vehicle shall be instrumented with measurement devices for measuring the necessary input values for the power calculation.

As an alternative to use of measurement devices, use of onboard measurement data for engine speed, intake manifold pressure, and fuel flow rate is permissible. Use of onboard measurement data for other measurements is permissible if the accuracy and frequency of these data is demonstrated to the responsible authority to meet the minimum requirements for accuracy and frequency described in 5.2. If TP1 is applied for the system power measurement and onboard measurement data is used for the confirmation of intake manifold pressure and fuel flow rate, the manufacturer has to ensure that values of those onboard measurement data has been recorded during R85 or ISO1585 certification.

Measurements common to both TP1 and TP2 include accelerator command, atmospheric pressure, room temperature, and the operational metrics listed in 6.8.1.

For the purpose of internal validation (see 6.10.), the power delivered by the vehicle to the dynamometer during the maximum power condition shall be recorded (for example, by recording dynamometer wheel speed and torque, or dynamometer power if available, at a minimum of 10 Hz).

6.1.2.1. Measurements specific to TP1

For TP1, the following measurements are additionally required: electrical current and voltage at the REESS or inverter inputs (as specified according to 6.1.3.1.), and ICE speed, intake manifold pressure, and fuel flow rate (if the hybrid power flow description indicates that an ICE contributes propulsion power during the maximum power condition). In this case, TP1 also requires an applicable full load power curve for the ICE, and in some cases may require conducting ISO 1585:1992 or UN Regulation No. 85 (as described in 6.9.2.1.).

If a DC/DC converter is powered by the REESS for the purpose of providing power to the 12-volt auxiliary bus, the manufacturer may elect to measure current and voltage at the input to the DC/DC converter in lieu of using the default of 1.0 kW.

If the hybrid power flow description indicates that high-voltage auxiliaries other than the above-mentioned DC/DC converter are powered by the REESS during the maximum power condition, the power consumed shall be measured or estimated (see 6.9.2.2.).

6.1.2.2. Measurements specific to TP2

For TP2, the following measurements are additionally required: torque and rotational speed at the powered axle shafts or wheel hubs.

Important: if the ICE power needs to be corrected according to the provisions of 6.9.3.2., the measurement requirements of TP1 with regard to current and voltage may also apply (see 6.9.3.3.).

Wheel torque and rotational speed measurement may be provided either by means of a hub dynamometer [or by means of system bench.] or by means of appropriate, calibrated measurement device(s) for torque and rotational speed of the powered axle shaft(s) or wheel hub(s) [or drive shafts].

If a powered axle delivers power to the wheels through a differential, it is sufficient to instrument and collect data from only one of the two drive shafts or wheel hubs. In this case, the measured torque at a drive shaft or wheel hub shall be multiplied by 2 in order to get the total torque per powered axle.

6.1.3. Test procedure applicability

Applicability of TP1 and TP2 varies with powertrain architecture, depending on the ability for one or the other procedure to determine the power at the reference point(s) that are applicable to the powertrain architecture.

The responsible authority shall confirm that the reference points identified in the hybrid power flow description are in accordance with the requirements of Annex 1 and the definition of "power determination reference point" in 3.5.

The responsible authority shall use the following considerations to determine applicability of TP1 and TP2 to the test vehicle. Where both TP1 and TP2 are applicable, the choice may be made by the manufacturer.

When reported for type approval, the vehicle system power rating that is determined by use of this GTR shall be identified as having been determined by either TP1 or TP2.

6.1.3.1. Applicability of TP1

Applicability of TP1 requires that the power passing through all reference points can be accurately determined by performing the prescribed procedure.

Subject to this requirement, TP1 is typically applicable if either of the following conditions 6.1.3.1.1. or 6.1.3.1.2. are fulfilled:

- 6.1.3.1.1. The hybrid power flow description indicates that the electrical current from each REESS powers a single electric machine, and current and voltage at the output of each REESS can be determined, and the manufacturer provides an accurate K1 factor representing the electrical conversion efficiency between the input to the inverter and the corresponding reference point.

Figure 16

Example of Case 6.1.3.1.1., TP1 applicable.

$$\text{Power at R [kW]} = (U \text{ [V]} * I \text{ [A]} / 1000) * K1$$

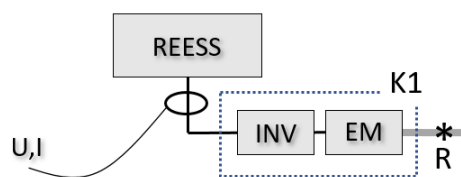

Or,

6.1.3.1.2. At least one of the following conditions (a) to (d) is fulfilled:

- (a) Current and voltage at the input to each inverter that is powered by the REESS can be determined, and the manufacturer provides accurate $K1(n)$ factors representing the electrical conversion efficiency between each input and the corresponding reference point(s).

Figure 17

Example of Case 6.1.3.1.2.(a), TP1 applicable.

$$\text{Power at R1 [kW]} = (U1 \text{ [V]} * I1 \text{ [A]} / 1000) * K1(1)$$

$$\text{Power at R2 [kW]} = (U2 \text{ [V]} * I2 \text{ [A]} / 1000) * K1(2)$$

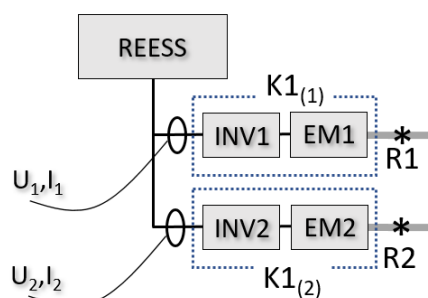

- (b) Current and voltage at the output of the REESS can be determined, and the manufacturer provides an accurate $K1_{comb}$ factor representing the combined electrical conversion efficiency of the inverters and electric machines between the REESS and the corresponding reference point(s).

Figure 18

Example of Case 6.1.3.1.2.(b), TP1 applicable

$$\text{Power at (R1+R2) [kW]} = (U \text{ [V]} * I \text{ [A]} / 1000) * K1_{comb}$$

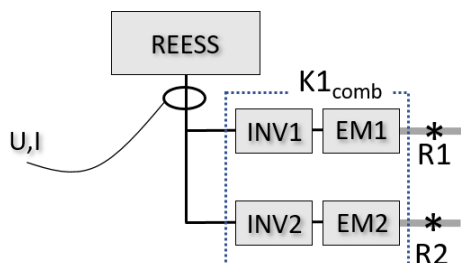

- (c) Current and voltage at the output of the REESS can be determined, and the electrical conversion efficiency between the input to each inverter and the corresponding reference point is identical and is thus represented by the same $K1$ factor.

Figure 19
Example of Case 6.1.3.1.2.(c), TP1 applicable
Power at (R1+R2) [kW] = (U [V] * I [A] / 1000) * K1

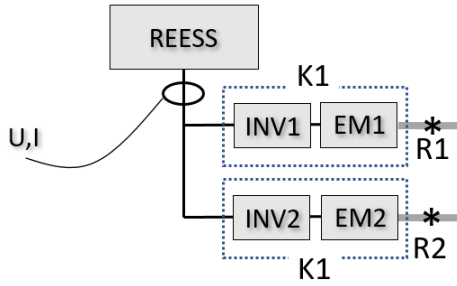

- (d) Current and voltage at the output of the REESS can be determined, and the distribution ratio ($DR_{(1)}$ and $DR_{(2)}$), which represents the relative distribution of power to R1 and R2, respectively, can be accurately determined by reference to onboard torque command values.

Figure 19a
Example of Case 6.1.3.1.2.(d), TP1 applicable
Power at R1 [kW] = (U [V] * I [A] / 1000) * K1(1) * DR₍₁₎
Power at R2 [kW] = (U [V] * I [A] / 1000) * K1(2) * DR₍₂₎

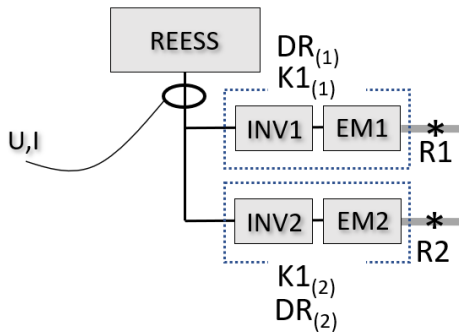

6.1.3.2. Applicability of TP2

Applicability of TP2 requires that the power passing through all reference points can be accurately determined by performing the prescribed procedure. Each powered axle is to be evaluated separately. TP2 is applicable only if it is applicable to all powered axles.

Subject to these requirements, TP2 is typically applicable to a powered axle if either of the following conditions 6.1.3.2.1. or 6.1.3.2.2. are fulfilled:

- 6.1.3.2.1. The hybrid power flow description indicates that torque to the axle originates from a single reference point, and the torque from the reference point is routed only to that axle, and the manufacturer provides an accurate K2 factor representing the mechanical conversion efficiency between the reference point and the measurement point.

Figure 20

Example of Case 6.1.3.2.1., TP2 applicable to axle.

$$\text{Power at R1 [kW]} = (2\pi * \tau \text{ [Nm]} * \text{rps [s-1]} / 1000) / K2$$

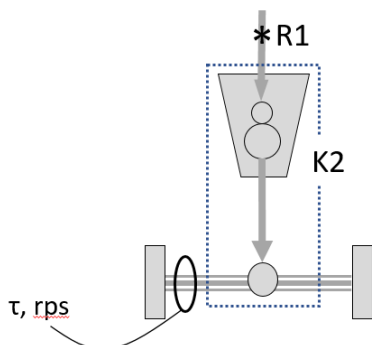

Note: measurement point represents both axle shafts.

Or,

- 6.1.3.2.2. The hybrid power flow description indicates that torque to the axle is a combined torque consisting of torque contributions from a set of reference points, and all of the torque contributions are routed only to that axle via the same mechanical energy path between the set of reference points and the measurement point, and the manufacturer provides an accurate $K2$ factor representing the mechanical conversion efficiency between the set of reference points and the measurement point.

Figure 21

Example of Case 6.1.3.2.2., TP2 applicable to axle.

$$\text{Power at (R1+R2) [kW]} = (2\pi * \tau \text{ [Nm]} * \text{rps [s-1]} / 1000) / K2$$

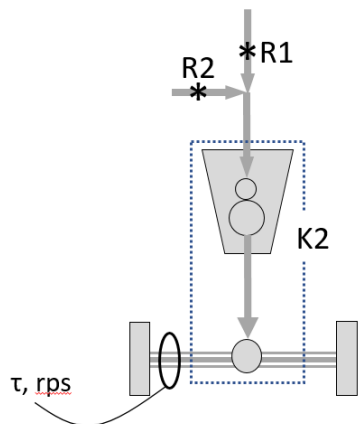

Note: measurement point represents both axle shafts.

TP2 is not applicable to an axle if torque contributions from more than one reference point are transmitted to the axle via different mechanical energy paths, for example, as shown in Figure 22.

Figure 22

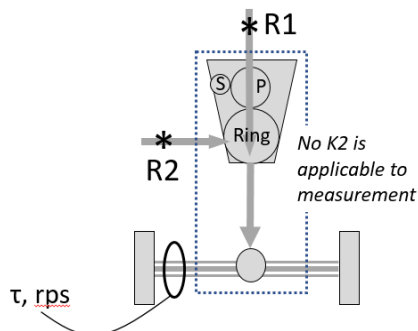
Example of TP2 not applicable to axle.**Power at R1, R2, or (R1+R2) cannot be resolved from the available measurement**

Note: measurement point represents both axle shafts.

6.2. Preparation of dynamometer

6.2.1. Roller (chassis dynamometer only)

Chassis dynamometer roller(s) shall be clean, dry and free from foreign material which can cause tire slippage.

6.2.2. Tire slippage (chassis dynamometer only)

Measures shall be taken to stabilize tire slippage that may occur during maximum power. The use of and amount of any additional weight placed in or on the vehicle, or the use of other measures for this purpose, shall be recorded.

6.2.3. Dynamometer warm-up

The dynamometer shall be warmed up in accordance with the dynamometer manufacturer's recommendations, or as appropriate, so that the frictional losses of the dynamometer may be stabilized.

6.2.4. Dynamometer control

For vehicle conditioning (6.8.3.), the dynamometer shall be controlled in road load mode or as allowed according to the provisions therein. For the power test (6.8.6), the dynamometer shall be controlled in fixed speed mode.

6.3. Preparation of vehicle

The vehicle shall be presented in good technical condition and shall be run-in in accordance with the manufacturer's recommendations.

OVC-HEVs and NOVC-HEVs shall have been run-in and driven between 3,000 and 15,000 km before the test. The engine, transmission and vehicle shall be run-in in accordance with the manufacturer's recommendations.

PEVs shall have been run-in at least 300 km or one full charge distance, whichever is longer.

The vehicle shall be fitted with tires of a type specified as original equipment by the vehicle manufacturer. The tires shall be inflated to a pressure in accordance with the vehicle manufacturer's recommendations or the owner's manual. If needed to adjust for the effect of added weight to prevent slippage (see 6.2.2.), tire pressure may be increased by up to 50 per cent above the lower limit of the tire pressure range for the respective axle for the selected tire at the coast-down test mass, as specified by the vehicle manufacturer. The same tire pressure shall be used for the setting of the dynamometer and for all subsequent testing. The tire pressures used shall be recorded.

The vehicle lubricants and levels specified by the manufacturer shall be used.

Fuel shall be the same fuel that was used for certification of the ICE, if equipped. For example, the fuel specified in UN ECE Regulation No. 85 shall be used for vehicles equipped with an ICE certified under that regulation.

6.4. Preparation of measurement devices

The measurement devices shall be installed at suitable position(s) within the vehicle.

6.5. Initial charge of REESS

For PEVs and OVC-HEVs, prior to or during vehicle soak (6.6), the REESS shall be charged to an initial SOC at which maximum system power is obtained. The manufacturer may specify the initial SOC at which maximum system power is obtained.

The initial charge of the REESS shall be conducted at an ambient temperature of 20 ± 10 °C.

The REESS shall be charged to the initial SOC in accordance with the procedure specified by the manufacturer for normal operation until the charging process is normally terminated.

The SOC shall be confirmed by a method provided by the manufacturer.

6.6. Vehicle soak

The vehicle shall be soaked in the soak area for a minimum of 6 hours and a maximum of 36 hours with the engine compartment cover opened or closed. The manufacturer may recommend a specific soak time or range of soak times within the range of 6 to 36 hours if necessary to ensure temperature stabilization of the high voltage battery. The soak area conditions during soak shall be as specified in 5.1.4.

6.7. Vehicle installation

The vehicle shall be installed on the dynamometer in accordance with the dynamometer manufacturer's recommendation, or regional or national regulations.

Auxiliary devices shall be switched off or deactivated during dynamometer operation unless their operation is required by regional legislation.

If necessary to operate properly on the dynamometer, the vehicle's dynamometer operation mode shall be activated by using the manufacturer's instruction (e.g. using vehicle steering wheel buttons in a special sequence, using the manufacturer's workshop tester, removing a fuse).

The manufacturer shall provide the responsible authority a list of the deactivated devices and justification for the deactivation. The dynamometer operation mode shall be approved by the responsible authority and the use of a dynamometer operation mode shall be recorded.

The vehicle's dynamometer operation mode shall not activate, modulate, delay or deactivate the operation of any part that affects the emissions, fuel or energy consumption, or maximum power under the test conditions. Any device that affects the operation on a dynamometer shall be set to ensure a proper operation.

Measurement devices installed within the vehicle shall be warmed up as appropriate.

6.8. Test sequence

6.8.1. General

The test shall be carried out in accordance with 6.8.3. to 6.8.8., and 6.9. to 6.10. (see Figure 23). The test shall be stopped immediately if warning indicator(s) with regard to the powertrain turns on.

Note: Warnings are coolant temperature and engine check lamp, for example.

The following operational metrics, if present, shall be monitored and recorded throughout the test: (a) engine coolant temperature, (b) battery temperature (as indicated by temperature of battery cells, modules, or pack, as available), (c) transmission or gearbox oil temperature, (d) battery SOC, (e) electric machine temperature (as indicated by temperature of stator, rotor, or cooling fluid, as available). The manufacturer shall specify the normal operating range for each operational metric.

6.8.2. Speed of maximum power

If the manufacturer has not provided the speed of maximum power, or the responsible authority wishes to verify the provided value, determine the speed of maximum power by the procedure described in Annex 2.

6.8.3. Vehicle conditioning

The measurement devices shall start collecting data.

The object of conditioning is to operate the vehicle until the normal operating temperature ranges specified by the manufacturer (6.1.1.4.) for the temperature-related operational metrics (6.8.1.) have been reached and have stabilized.

Prior to the test, perform initial conditioning by placing the vehicle in the power-rating mode, if applicable (see 6.8.5.), and run at the speed of 60 km/h at the vehicle road load for at least 20 minutes, or as recommended by the vehicle manufacturer. The vehicle manufacturer or the responsible authority may specify a different time period, speed, driver-selectable mode, dynamometer mode, or cycle, as necessary to achieve stable operating metrics.

At the end of initial vehicle conditioning, the operational metrics (see 6.8.1.) shall be recorded.

During the test, monitor the operating metrics and perform additional conditioning as necessary to maintain the operating metrics within the normal operating temperature ranges.

6.8.4. REESS adjustment

During vehicle conditioning according to 6.8.3., the SOC shall be monitored. The SOC shall be adjusted at the end of vehicle conditioning to the SOC at which maximum system power is obtained as recommended by the manufacturer. REESS adjustment also applies to power test repetitions as directed in 6.8.7.

REESS adjustment may be performed by use of light regenerative braking, or by allowing the vehicle to coast, while the dynamometer is operated in fixed speed mode, or as recommended by the manufacturer. The charge rate by either method shall be monitored and shall be limited as recommended by the manufacturer to avoid undue heating of the battery or de-rating of the battery power.

6.8.5. Vehicle operation

For vehicles that have driver-selectable modes, the vehicle system power rating that is determined by this procedure may depend on which mode is active during the test. Select the mode for which a vehicle system power rating is desired.

The selected mode shall be recorded as the power-rating mode.

Place the dynamometer in fixed speed mode.

Set the dynamometer fixed speed to the speed of maximum power and allow the speed to stabilize.

6.8.6. Power test

The maximum accelerator command shall be given by either fully depressing the accelerator pedal or by vehicle communication network for a duration of at least 10 s.

The maximum accelerator command shall be given as rapidly as possible. If necessary in order to elicit maximum power delivery, it is permissible to vary the accelerator command as recommended by the manufacturer prior to the maximum accelerator command (for example, ask the manufacturer if it is necessary to achieve a kickdown state).

If the gearbox has driver-selectable gears, the gear shall be selected as recommended by the manufacturer for a typical driver to achieve maximum power. Gear shifting by means of special modes or actions that are not available to a typical driver are not permitted.

6.8.7. Repetition of power test

The power test of 6.8.6. shall be repeated for a total of five repetitions as shown in Figure 23.

Prior to the second and subsequent repetitions, the REESS shall be adjusted according to 6.8.4.

The temperature-related operational metrics listed in 6.8.1. shall be monitored during all repetitions and seen to remain within the normal operating range specified by the manufacturer during each repetition. Re-condition the vehicle according to 6.8.3. between repetitions if necessary.

Figure 23

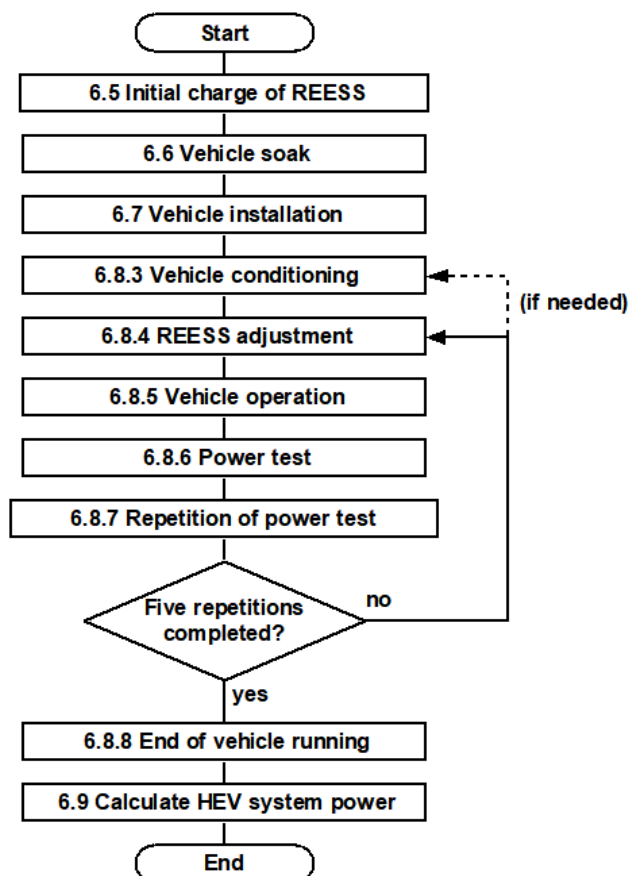
Test sequence

6.8.8. End of vehicle running

At the end of vehicle running, the operational metrics (see 6.8.1.) shall be recorded.

After the measurements are complete, the vehicle and measurement devices shall be stopped.

6.9. Calculation of vehicle system power rating

6.9.1. General

For each of the 2nd through 5th repetitions according to 6.8.7., time series data obtained from 6.8 shall be analyzed to calculate vehicle system power.

For each repetition, two power calculations shall be performed:

- (a) Peak vehicle system power: a 2-second "peak" power that is the maximum value of a 2-second moving average filter applied for the 10-second measurement time; and
- (b) Sustained vehicle system power: a "sustained" power that defines the average power within the measurement time window from 8 s to 10 s.

For computation purposes, the 10-second measurement time window begins when the accelerator command has reached maximum as indicated by the accelerator command measurement, and the gear ratio (if changed) has begun a period in which it is constant for at least 10 seconds.

If the vehicle design does not provide for a stable gear ratio to be achieved for a full 10 seconds under the maximum power condition, the time window may begin according to the manufacturer's recommendation, with the approval of the responsible authority.

Finally, compute the peak and sustained vehicle system power ratings for the vehicle, as the mean of the respective individual results of the four analyzed repetitions.

The variation of each of the four analyzed repetitions shall be computed as a percentage of their mean, and recorded.

The maximum variation of an individual value should not be greater than $\pm 5\%$ of the mean. If the variation is too large, check the dynamometer settings and vehicle configuration, consult with the manufacturer for possible causes, and perform the repetitions again. If variation cannot be reduced, the system power rating is subject to approval by the responsible authority.

6.9.2. Calculation for TP1

The vehicle system power is calculated as the sum of the power at each of the reference points:

$$\text{Vehicle system power [kW]} = \sum_{i=1}^n R_i$$

where

n is the number of power determination reference points

R_i is the power at the i^{th} reference point [kW]

The power at each R_i is determined according to 6.9.2.1. through 6.9.2.3.:

6.9.2.1. For reference points consisting of ICE power:

First determine the ICE power by reference to the full load power curve as a function of engine speed, applicable to the engine that is installed in the vehicle, and subject to confirmation of intake manifold pressure and fuel flow

rate. The full load power curve shall be derived from the applicable engine test standard and shall be measured under steady state conditions.

For manufacturers to which engine certification by ISO 1585 or UN Regulation 85 is applicable by regulation, the applicable engine test standard is ISO 1585:1992 or UN Regulation No. 85, respectively. For other manufacturers, the applicable standard is that which is applicable by local or regional regulation. In the case that no engine test standard is applicable by regulation, the applicable standard is SAE J1349 (steady state). The engine dynamometer test fuel shall be as specified in the applicable standard.

To confirm intake manifold pressure and fuel flow rate, compare the measured values to those reported in the certification results of the applicable standard at the measured engine speed.

If:

$$\begin{aligned} & |(measured\ fuel\ flow\ rate - fuel\ flow\ rate\ at\ certification)| \\ & < (0.05)(fuel\ flow\ rate\ at\ certification) \end{aligned}$$

and

$$\begin{aligned} & |(gauge\ pressure\ at\ test - gauge\ pressure\ at\ certification)| \\ & < (0.05)(intake\ manifold\ pressure\ at\ certification) \end{aligned}$$

then R_i is the power indicated by the full load power curve at the measured engine speed.

Otherwise, determine R_i by conducting ISO 1585:1992 or UN Regulation No. 85 (as applicable) under the observed conditions using the above-measured engine speed, intake manifold pressure and fuel flow rate, or ask the vehicle manufacturer for support in determining the ICE power under the observed conditions.

Note: if any portion of R_i is routed to charge the REESS, the electrical power entering the REESS shall be accounted for as negative power under 6.9.2.2.

6.9.2.2. For reference points consisting of electric machine power, and where the measurement point is the REESS output:

R_i shall be determined by the equation:

$$R_i [kW] = \left(\frac{U_{REESS} \times I_{REESS}}{1000} - P_{DCDC} - P_{aux} \right) \times K1$$

where

U_{REESS} is the measured REESS voltage [V]

I_{REESS} is the measured REESS current [A] (negative if flowing into the REESS)

P_{DCDC} is the power to DC/DC converter for 12V auxiliaries, if present (either 1.0 kW or measured value) [kW]

P_{aux} is the power to high-voltage auxiliaries powered by the REESS, other than P_{DCDC} , if present and operating during the test (measured or estimated value) [kW]. If estimated, the manufacturer shall provide evidence supporting the estimated value. Use of the estimated value is subject to approval by the responsible authority.

$K1$ is the conversion factor from DC electrical power to mechanical power as described in 6.1.1.2. and 6.1.3.1.

If $K1$ represents a conversion to the sum of the power at a set of reference points (for example, (R_1+R_2) as depicted in Figure 18), the equation computes the sum of the power at the set of reference points.

If P_{DCDC} and P_{aux} are measured, they are calculated as:

$$P_{DCDC} [kW] = (U_{DCDC} \times I_{DCDC}) / 1000$$

$$P_{aux} [kW] = (U_{aux} \times I_{aux}) / 1000 \quad (\text{for each applicable auxiliary})$$

where

U_{DCDC} is the voltage to DC/DC converter for 12V auxiliaries [V]

I_{DCDC} is the current to DC/DC converter for 12V auxiliaries [A]

U_{aux} is the voltage to the auxiliary [V]

I_{aux} is the current to the auxiliary [A]

6.9.2.3. For reference points consisting of electric machine power, and where the measurement point is the inverter input:

R_i shall be determined by the equation:

$$R_i [kW] = \left(\frac{U_{Input} \times I_{Input}}{1000} \right) \times K1$$

where

U_{Input} is the measured DC voltage at the inverter input [V]

I_{Input} is the measured current at the inverter input [A]

$K1$ is the conversion factor from DC electrical power to mechanical power as described in 6.1.1.2. and 6.1.3.1.

If $K1$ represents a conversion to the sum of the power at a set of reference points (for example, if the inverter powers a set of electric machines), the equation computes the sum of the power at the set of reference points.

6.9.3. Calculation for TP2

6.9.3.1. Calculation

The vehicle system power is calculated as the sum of the power at each of the reference points:

$$Vehicle\ system\ power\ [kW] = \sum_{i=1}^n R_i$$

The power at each reference point is calculated as:

$$R_i [kW] = \left(\frac{P_{axle}}{K2} \right)$$

Where

P_{axle} is the power measured at the respective powered axle [kW]:

$$P_{axle} [kW] = (2\pi \times axle\ shaft\ or\ wheel\ speed [rev \cdot s^{-1}] \times axle\ shaft\ or\ wheel\ torque [Nm]) / 1000$$

$K2$ is the mechanical energy conversion efficiency factor $K2$ applicable to the axle as described in 6.1.1.2. and 6.1.3.2.

If $K2$ represents a conversion to the sum of the power at a set of reference points (for example, $(R1+R2)$ as depicted in Figure 21), the equation computes the sum of the power at the set of reference points.

6.9.3.2. ICE power correction

The ICE power portion of the vehicle system power rating shall be corrected according to the provision given in ISO 1585:1992 clause 6, if:

— the reference atmospheric and temperature conditions, given in ISO 1585:1992 clause 6.2.1; or

— the automatic control conditions according to ISO 1585:1992, clause 6.3 cannot be fulfilled.

Note: if the applicable standard according to 6.9.2.1. is not ISO 1585 (for example, UN Regulation No. 85), ICE power correction shall be performed according to the equivalent portions of the applicable standard (for example, UN Regulation No. 85 clause 5).

If the ICE power portion needs to be corrected, follow 6.9.3.3., otherwise continue with 6.10.

6.9.3.3. Corrected vehicle system power rating for TP2

ICE power correction requires a distinct value for the ICE power portion (P_{ICE}) of the vehicle system power rating.

For many powertrain architectures, TP2 does not deliver a distinct value for the ICE power portion. For example, Figure 24 shows a powertrain where TP2 would apply a K2 factor to the power measured at the axles, delivering the sum of R1 (P_{ICE}) and R2 ($P_{non-ICE}$) instead of a distinct value for each.

Figure 24
Example of powertrain where TP2 does not deliver a distinct value for ICE power (R1)

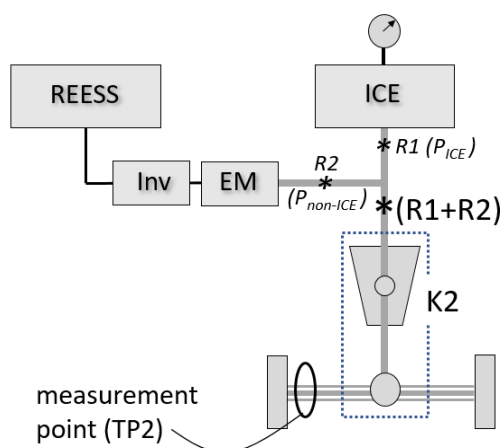

Note: measurement point represents both axle shafts.

If TP2 does not provide a distinct value for P_{ICE} , perform steps (a) through (c) below to derive P_{ICE} by subtracting the power at the non-ICE reference points that were summed with the ICE reference point.

Otherwise, proceed with step (d).

- Identify the set of summed reference points that includes the ICE reference point, and their summed power as delivered by TP2 (P_{summed}).
- Perform TP1 to determine the power at each of the non-ICE reference points in the set, and sum them together to determine the non-ICE portion ($P_{summed, non-ICE}$).
- Subtract the power at the non-ICE reference points ($P_{summed, non-ICE}$) from the summed power (P_{summed}). The result is the measured ICE power, P_{ICE} :

$$P_{ICE} [kW] = P_{summed} [kW] - P_{summed, non-ICE} [kW]$$

- Correct the measured ICE power according to ISO 1585:1992 (or the applicable standard, if different, according to 6.9.2.1):

$$P_{ICE, corrected} [kW] = P_{ICE} [kW] \times (\text{Power correction factor})$$

where *Power correction factor* is according to ISO 1585:1992, clause 6 (or the equivalent portion of the applicable standard, if different, according to 6.9.2.1).

- (e) Compute the corrected vehicle system power rating as the sum of the corrected ICE power and the power at all non-ICE reference points in the powertrain:

$$\text{Vehicle system power}_{corrected} [kW] = \left(\sum R_{all\ non-ICE} [kW] \right) + P_{ICE,corrected} [kW]$$

Note: Ask the manufacturer if the vehicle control system adjusts the power output of electric machine(s) to electrically compensate for variation in ICE power output due to altitude or air temperature. In this case, the amount of electrical compensation shall be subtracted from the vehicle system power rating after the power correction is performed.

6.10. Internal validation of vehicle system power rating

The vehicle system power rating according to TP1 or TP2 shall fulfill the following requirement:

The implied downstream efficiency between the reference point(s) and the road shall not be greater than 1. Implied downstream efficiency is computed by dividing the average power recorded at the dynamometer rollers (or hub ~~dyno~~ dynamometer [or system bench] if applicable) between the 8th and 10th second by the sustained vehicle system power result (prior to any correction under 6.9.3.3).^[M85]

7. Definitions of families

7.1. General

Vehicles having the same characteristics with respect to their evaluation for system power may be grouped into vehicle families for the purpose of determining a system power rating considered to be applicable to all vehicles in the family.

7.2. Family definition

Only vehicles that are the same with respect to all of the following elements may be part of the same family:

- (a) Powertrain system configuration, including number, type, and mechanical arrangement of power sources and operating strategy;
- (b) ICE power rating;
- (c) Net power and construction type (for example, asynchronous, synchronous, or other specific construction type) of all electric machines in the powertrain, and type of electric energy converter(s) between the electric machine(s) and the battery;
- (d) Type of battery cell, including format, capacity, voltage, and chemistry;
- (e) Type of battery pack, including battery configuration (number of cells in series and mode of connection);
- (f) Nominal voltage of the battery;
- (g) Maximum current of the battery; and
- (h) Type of vehicle (PEV, OVC-HEV, or NOVC-HEV).

At the request of the manufacturer, with the approval of the responsible authority and with appropriate technical justification, the manufacturer may deviate from the above criteria.

Annex 1

Identification of power determination reference points

1. General approach
 - 1.1. Both TP1 and TP2 convert a set of specified vehicle test measurements to a vehicle system power rating that represents the mechanical power transmitted through one or more power determination reference points.
 - 1.2. Power determination reference points are intended to represent points in the mechanical power flow path of an electrified powertrain that are most analogous to the engine output shaft in a conventional vehicle. Here, “analogous” means being a point in the powertrain where mechanical power that drives the wheels is first produced from stored energy. This is consistent with the tradition that conventional vehicles are assigned a system power rating equal to the rated power of the engine, without consideration of the power losses that occur downstream of the engine output shaft.
 - 1.3. A power determination reference point is a point in the mechanical power flow path of an electrified powertrain as defined in paragraph 3.5. In the most general sense, reference points represent where the mechanical power that drives the wheels during the maximum power condition is first produced from an energy storage system. A given electrified powertrain may include one or more power determination reference points as necessary to account for all sources of propulsion power to the powered axle(s). The vehicle system power rating is the sum of the power transmitted through all of the reference points.
 - 1.4. Reference points for complex electrified powertrains can vary depending on the specific power flow paths that are active in a given operating mode of the vehicle or at a given power demand. For the purpose of system power determination under this GTR, reference points shall be identified according to the requirements of this Annex.
 - 1.5. Calculation of the vehicle system power rating under both TP1 and TP2 shall result in an estimate of the sum of the power at all of the identified reference points during the maximum power condition. The same reference points shall apply to a given powertrain regardless of whether TP1 or TP2 is applied.
2. Identifying power determination reference points
 - 2.1. General considerations
 - 2.1.1. Power determination reference points represent all of the sources of the total mechanical power that is transmitted to the road during the maximum power condition. This means that they are based not only on powertrain architectural layout but also on the state of the powertrain during the maximum power condition and on any applicable operating mode. Propulsion energy converters that are not operating or are not contributing propulsion energy to the road in this state are not included.
 - 2.2. Parallel architectures
 - 2.2.1. The power determination reference points for parallel architectures (example in Figure 25) are generally (a) the engine mechanical power output shaft and (b) the mechanical power output shaft(s) of any electric machines that provide mechanical power to the road. The vehicle system power rating is the sum of the power passing through the reference points.

Figure 25
Example of power determination reference points R1 and R2 for a simple parallel architecture.

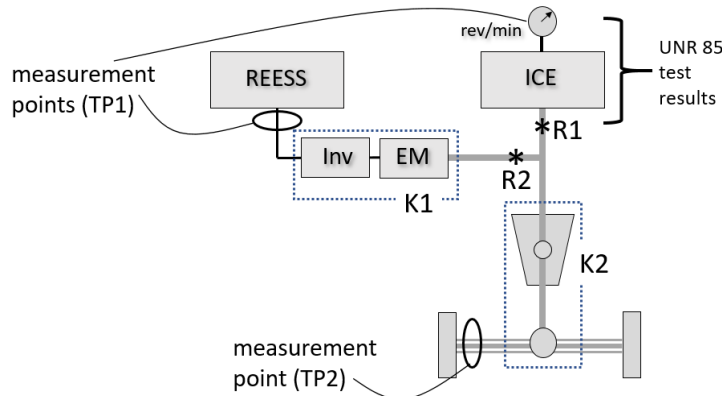

Note: measurement point for TP2 represents both axle shafts.

- 2.2.2. In Figure 25, the electric machine EM directly drives the engine output shaft. The reference points are R1 and R2.
- 2.2.3. Here TP1 may be performed by measuring engine speed, manifold pressure, and fuel flow rate (with reference to the full load power curve) to determine the power at R1, and measuring REESS current and voltage (corrected by K1) to determine the power at R2.
- 2.2.4. TP2 may be performed by measuring the torque and speed at the drive wheels or axle hubs (corrected by K2) to determine the sum of R1 and R2.
- 2.3. Power split architectures
- 2.3.1. Power split architectures (example, Figure 26) often have more than one input and/or output to a complex gearbox that may include one or more planetary gear sets, and may also include a series power conversion path that mixes power from the ICE with power from the REESS. The power determination reference points for such an architecture are generally (a) the engine mechanical power output shaft and (b) the mechanical power output shaft(s) of any electric machines that provide mechanical power to the road. With regard to (b), in the case that the mechanical power delivered by the electric machine includes power sourced from the ICE, only the portion of the power that originates from the REESS is counted (R2REESS in Figure 26). The vehicle system power rating is the sum of the power passing through R1 and R2REESS.

Figure 26
Example of power determination reference points R1 and R2REESS for a simple power split architecture.

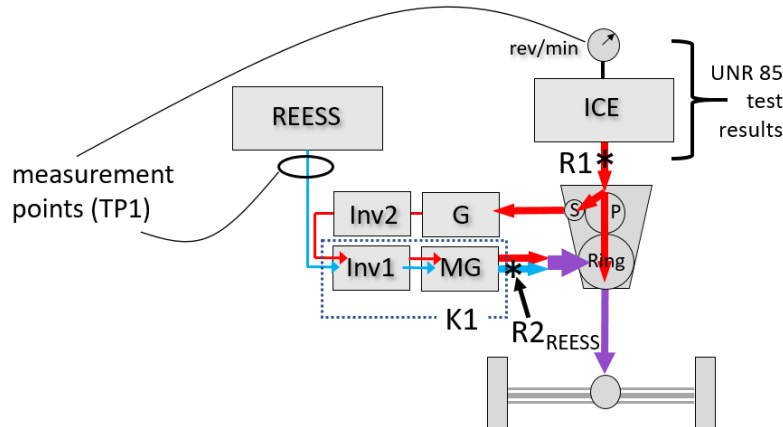

- 2.3.2. Here, TP1 may be performed by measuring engine speed, manifold pressure, and fuel flow rate (with reference to the full load power curve) to determine the power at R1, and measuring REESS current and voltage (corrected by K1) to determine the power at R2_{REESS}. K1 should be chosen to represent the net efficiency of the Inv1+MG combination when transmitting all of the depicted power (of both the series path and the REESS).
- 2.3.3. As indicated by the applicability guidelines under 6.1.3.2, TP2 is not applicable because the power arriving at the axle is a combination of power flows that experience different conversion efficiencies, making it impractical to reconstruct the power at R1 and R2_{REESS} from a single measurement of axle power.
- 2.4. Pure series architectures
- 2.4.1. Pure series architectures (example, Figure 27) include an ICE that powers one or more electrical conversion paths with no mechanical link between the engine and the road. The power determination reference points are generally (a) the engine mechanical power output shaft and (b) the mechanical power output shaft(s) of any electric machines that provide mechanical power to the road. With regard to (b), in the case that the mechanical power delivered by an electric machine includes power sourced from the ICE, only the portion of the power that originates from the REESS is counted (R2_{REESS}). The vehicle system power rating is the sum of the power passing through R1 and R2_{REESS}.

Figure 27

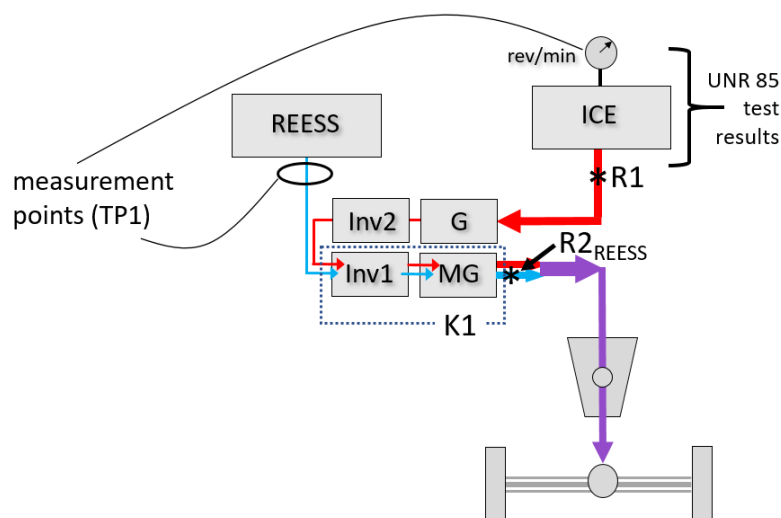
Example of power determination reference points for a pure series architecture

- 2.4.2. Here, TP1 may be performed by measuring engine speed, manifold pressure, and fuel flow rate (with reference to the full load power curve) to determine the power at R1, and measuring REESS current and voltage (corrected by K1) to determine the power at R2_{REESS}. K1 should be chosen to represent the net efficiency of the Inv1+MG combination when transmitting all of the depicted power (of both the series path and the REESS).
- 2.4.3. As indicated by the applicability guidelines under 6.1.3.2., TP2 is not applicable because the power arriving at the axle is a combination of power flows that experience different conversion efficiencies, making it impractical to reconstruct the power at R1 and R2_{REESS} from a single measurement of axle power.
- 2.5. Architectures with more than one powered axle
- 2.5.1. When more than one axle propels the vehicle under the maximum power condition, the vehicle must be tested at both axles simultaneously. If each axle is not powered by the same set of propulsion energy converters, there will

commonly be reference points associated with a specific axle. An example is shown in Figure 28. Power at R1 and R2 is delivered to one axle while power at R3 is delivered to the other axle. The vehicle system power rating is the sum of the power passing through R1, R2, and R3.

Figure 28
Example of an architecture with more than one powered axle each receiving power through different reference points

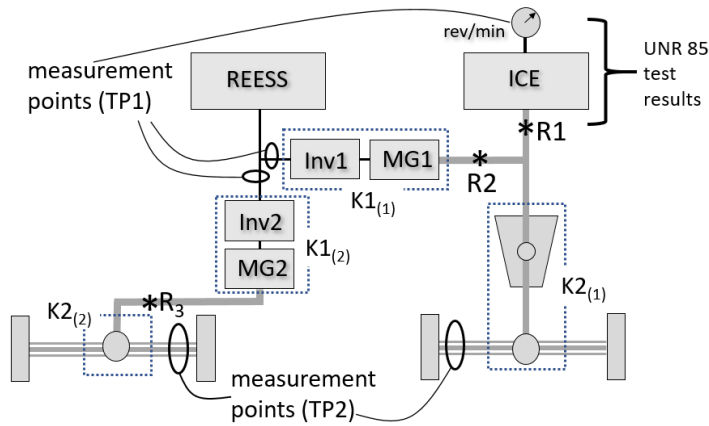

Note: measurement points for TP2 represent both axle shafts.

- 2.5.2. Here, TP1 may be performed by measuring engine speed, manifold pressure, and fuel flow rate (with reference to the full load power curve) to determine the power at R1, and measuring the current and voltage at the input to each of Inv1 and Inv2 (correcting by K1(1) and K1(2), respectively) to determine the power at R2 and R3 (alternatively, instrumentation of the REESS instead of the inverters may be applicable under the conditions described in 6.1.3.1.).
- 2.5.3. TP2 may be performed by measuring the torque and speed at the right-side axle (corrected by K2(1)) to determine the sum of R1 and R2, and measuring the torque and speed at the left-side axle (corrected by K2(2)) to determine R3.
- 2.6. Other architectures
- 2.6.1. Reference points for other architectures not listed in this Annex, or for variations in the listed architectures, shall be selected in conformity with the definition of power determination reference point in 3.5. and in a manner consistent with the principles and guidelines discussed herein. Selection of power determination reference points is subject to approval by the responsible authority.

Annex 2

Determination of speed of maximum power

1. The speed of maximum power (defined in 3.5.) is the maximum value in the relation between power and speed (see Figure 29), where power is the power delivered to the dynamometer and speed is the speed of the vehicle operating in fixed speed mode on a dynamometer.
2. The speed of maximum power shall be determined either by the manufacturer or the responsible authority by the procedure described in this Annex.
3. The speed of maximum power shall be identified by conducting the test sequence depicted in Figure 30 at a series of operating points (fixed vehicle speeds) in order to identify the speed at which maximum power occurs.
4. The series of operating points should be spaced closely enough to identify the speed of maximum power with good confidence. The operating points may initially be chosen to cover a range of speeds at a coarse resolution, followed by a finer resolution to identify the speed where peak power is obtained.
5. The power delivered to the dynamometer at each operating point may be determined by reference to dynamometer power data, or dynamometer speed, and torque, or force data, where available. [JM36]
6. Once determined, the speed of maximum power shall be reported in kilometres per hour [or revolutions per second] [RRC37][JM38] as a whole number.
7. If the vehicle manufacturer has specified the speed of maximum power and verification is desired, run at slightly different speeds above and below the specified speed to confirm that a peak exists at the specified speed.

Figure 29

Relation between power and speed

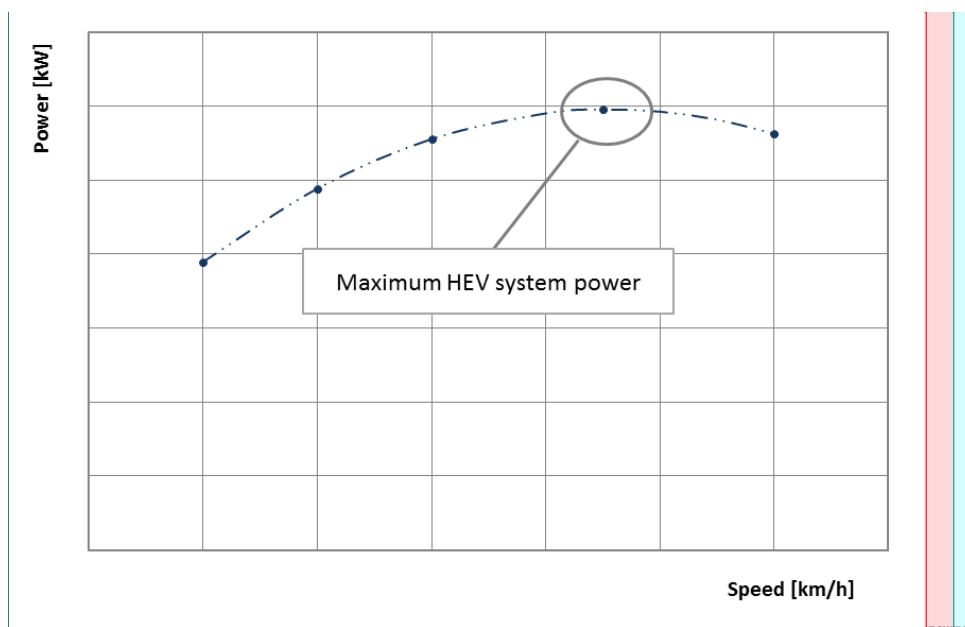
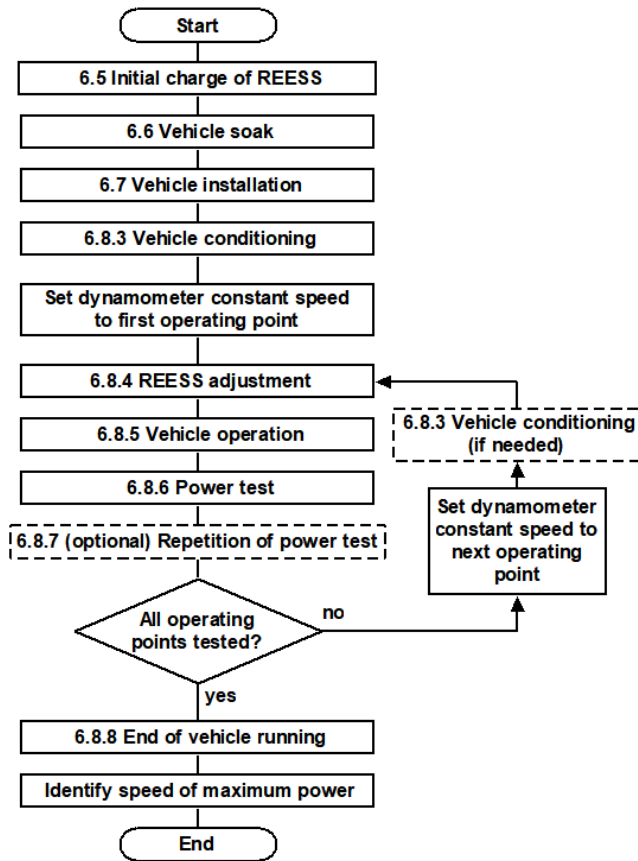

Figure 30
Test sequence for determination of speed of maximum power



[Annex 3^{M411}]Approval of the system bench facility by the responsible authority^{M446}

The results of the system bench testing shall be compared to those obtained using the chassis dynamometer to demonstrate qualification of the facility and recorded.

1. Test procedure

1.1 Two vehicles covering the maximum and minimum outputs of the vehicles planned to be measured with the facility shall be selected, and their respective system power values shall be obtained by testing with a chassis dynamometer in accordance with paragraph 6. and by using the system bench facility concerned.

2. Approval criteria

2.1 The facility used shall be approved if both of the following two criteria are fulfilled:

(a) The difference between the chassis^{M447} dynamometer test results in accordance with paragraph 6. of this document and the results from the relevant system bench facility for each vehicle shall be within $[\pm 0.05]$:

$$P_k = \frac{P_{k,SB} - 1}{P_{k,DM}}$$

where

P_k is the difference in system power for vehicle k between the system bench and the chassis dynamometer, in percent

$P_{k,SB}$ is the system power value obtained at the system bench testing, in kilowatts

$P_{k,DM}$ is the system power value obtained at the dynamotor testing in accordance with paragraph 6., in kilowatts.

(b) The arithmetic average \bar{x} of the two differences shall be within $[0.02]$.

$$\bar{x} = \left| \frac{P_1 + P_2}{2} \right|$$

2.2 The approval shall be recorded by the responsible authority including measurement data and the facilities concerned.

2.3 The facility may be used for system power determination for five years after the approval has been granted or until prior to major maintenance.

2.4 In the case of vehicles whose maximum power, in the judgment of the responsible authority,^{M448} exceeds that of readily available dynamometers, it is permissible to use a system bench, which may include simulators, in place of a dynamometer, ^{M449}without the comparison tests specified in this section.^{M450}

2.5 The manufacturer shall provide the most recent calibration data of the measurement equipment based on the request by the responsible authority.